

**Comhairle Contae Chorcaí**  
**Cork County Council**



**Cork County Council Public Lighting Manual and  
Product Specification 2023**



Jan 2023



<b><u>Contents:</u></b>	<b><u>Page:</u></b>
1. Introduction	5
2. Public Lighting Terminology	8
3. Objectives of Public Lighting	14
4. Types of Lighting Equipment	16
5. Public Lighting Design Criteria	22
6. Installation Procedure	43
7. General Technical Specification for Luminaries	48
8. Exterior Lighting Columns & Brackets	64
9. Compatibility of Components	70
10. Cable Design & Electrical Service Design	72
11. Small Civil Works – Access Chambers & Ducts	75
12. Electrical Supply – Metered & Un-metered	76
13. Lighting Engineering Consultants	78
14. Street Lighting – Equipment Manufactures & Suppliers	79
15. Electrical Contractors	80
16. Lighting of Pedestrian Crossings & Traffic Islands	82
17. Temporary Lighting	86
18. Night-time Lighting of Buildings & Structures	87
19. Floodlighting Schemes	89
20. Urban Street Lighting	93
21. Photovoltaic Lanterns (Solar Powered)	98
22. Documentation required with planning applications	102
23. Taking in Charge	104
24. Conclusion	107
References	108
Glossary of Terms	110
Appendix A- Ingress Protection	112
Appendix B - Taking in Charge Application Form	114
Appendix C – Typical Taking in Charge Report	117
Appendix D – Figures & Drawings	119

Appendix E – Sample Unmetered Application Form	138
Appendix F – Extract from TII Publications DN-LHT-03038 Aug 2018	140
Appendix G – Available dimming profiles	142
Appendix H - Planning Application documentation and Cork County Council’s menu of Standard Planning conditions	146
Appendix I – LED Lantern checklist for compliance	155
End of Document	156

## 1.0 Introduction

1.1 The purpose of this manual is to outline Cork County Council policies and to offer guidance on design etc. to ensure the development of a sustainable energy efficient public lighting network. ***Script in bold italics generally reflect specific Cork County Council policy.***

Cork County Council is seeking to foster coordination and consistency in the design, provision and maintenance of high quality street lighting throughout Cork County rural and urban areas. It seeks to avoid unnecessary and wasteful overlighting by ensuring that designs are completed for all new installations by a competent person using all available Lighting Design technology.

Lighting is a highly valued and visible asset with the potential to make a significant contribution to the wider community in terms of accessibility, security and the fostering of commercial activities. This Manual has accordingly been developed to provide a stimulus to the pursuit of continuous improvement and the flexibility to evolve with improving technology.

Cork County Council has achieved ISO 50,001 status on energy management and a key cornerstone of energy reduction is the gradual introduction of lower energy public lighting units across the county. Towards this end, ***Cork County Council policy requires the use of LED lighting on all new general public lighting schemes, inclusive of new housing estates.*** All new schemes are to be designed by a competent public lighting design professional, using appropriate software, ***incorporating the use of low energy, high quality recognised lantern brands, acceptable to the Cork County Council's Public Lighting Department and meeting the appropriate standards.***

All Street Lighting Schemes must meet the requirements of

- CEN code of practice EN 13201-1: 2015
- CEN code of practice EN 13201-5:2015 relating to Energy Benchmarking
- BS5489: 2013 (and any future updates to these documents).
- TII Publications DN-LHT-03038 for national Routes
- BS EN 12193:2018 for Sports Lighting
- Technical Report 12 Lighting of Pedestrian Crossings - 2007
- I.S. 10101:2020 and ET211:2003.
- ESB National Code of Practice for Customer Interface 5<sup>th</sup> Edition 2021<sup>16</sup>

***Cork County Council wishes to promote the installation of energy efficient exterior lighting schemes.*** Measures required to achieve this include the use of lanterns with high efficacy values, efficient optics to minimize light pollution, optimization of scheme layout, use of energy efficient lamps and electronic control gear, capable of factory set dimming, complying with best practice and taking account of the 'Campaign for Dark Skies' issues where appropriate.

Therefore all lighting schemes shall incorporate the requirements of, "Guidance notes for

the Reduction of Light Pollution” issued by the Institution of Lighting Professionals<sup>1</sup> and available as a download from its website Professionals [www.theilp.org.uk](http://www.theilp.org.uk).

***The lighting design for all new schemes and modifications to existing developments must include the upgrade of the lighting on junctions from the public road in addition to any lighting being provided within the development. It should also include connectivity of lighting from the development towards the Town/Village nucleus.***

There is also a need to ensure a continuity of illumination between the development and the town/village core, in cases where the development is on the outskirts of the town/village. The latter can be achieved either by the developer directly extending the existing lighting network or by the levying of a special contribution which would enable the County Council to carry out the works. ***The former is preferred.***

Where suitable, low brightness energy efficient lighting schemes should be considered with a view to enhancing the night-time scene combining improved security with modern shaped Lanterns. ***In general Cork County Council policy is to utilise warm white lighting ( 2,700-3,000) with exceptions for significant conflict areas such as roundabouts or pedestrian crossings, on a case by case basis.***

The installation of schemes in residential areas shall comply with the Code of Practice for Public Lighting ET211: 2003, ET 207:2003, ET 206:2009, ET 213:2007 and the National Rules for Electrical Installations, (IS 10101: 2020), current at time of issue and shall include the provision of a Customer Service Pillar(s) in line with the requirements of ESB Networks National Code Of Practice For Customer Interface (current edition).

Well maintained road lighting can change our communities, make the night time environment a safer place to be, encourage regeneration and investment, leading to an improved local economy and at the same time contributing to a more inclusive society.

However, these benefits are only achievable if the right decisions are made. This Manual comprises a framework of guidance, specifications, and references to standards, the application of which will make a significant contribution to the decision making process.

It is hoped that the adoption of the recommendations in this Manual will assist in delivering a better and safer night-time environment on the Cork County Council road network.

All queries pertaining to the design and maintenance of exterior lighting installations in Cork County should be directed to Cork County Council, Public Lighting Division at the contact details advised in Chapter 24 of this manual.

There are a number of developing technologies which aim to create more energy efficient Public Lighting Systems, and these need to be assessed on a continuous basis and implemented where appropriate. Another simpler form of energy efficiency involves consideration of the time period for which lighting can logically be deemed necessary.

The lighting of amenity walks etc. should only be required on a dusk to midnight basis unless there is a very compelling reason to extend further. Similarly with playgrounds

unless there is a compelling reason, such as anti-social behaviour, for lighting after dark.

The use of high wattage spotlights to light monuments/churches etc. is no longer acceptable as there are low wattage LED equivalents which provide similar levels of illumination and the need or otherwise for such monuments to be lit right through the night must be carefully considered. Warm white LED's (c 2,700k) are recommended.

## **2.0 Public Lighting Terminology**

### **2.1 CMS**

Central Management Systems (CMS), also known as telemanagement, is a useful tool in remote dynamic street lighting control. Using a CMS, the operator can choose exactly when to switch each individual street light on or off and/or by how much to reduce the lamp power. This allows any number of switching events and/or dimming levels. CMS also provides other benefits such as fault detection. CMS systems can be enabled using wireless systems or mains power. Cork County Council do not presently use CMS systems but may do at some point in the future.

### **2.2 LEDs**

Light Emitting Diodes (LED) emit a white light that provides high levels of scotopic lumens allowing street lights with lower wattages and lower photopic lumens than traditional High/Low Pressure Sodium (SON/SOX) street lights.

### **2.3 METAL HALIDE LAMPS**

These were traditionally used predominantly in the lighting of pedestrian crossings. LED equivalents are now available and must be used in new installations.

### **2.4 CLO**

All light sources experience lumen depreciation - a reduction in light output over time. The Constant Light Output (CLO) functionality compensates for this light loss, ensuring LEDs will always deliver the necessary light level.

By taking into account the lumen depreciation, the driver can be programmed to start at a dimmed level for a new luminaire and gradually increase power over the life of the light source, to maintain a constant light output, saving energy and extending the lifetime of the system.

***Such technology is to be incorporated into lanterns erected in Cork County.***

### **2.5 DIMMING & TRIMMING**

**Dimming** is the process of reducing the current and consequently the lighting intensity during periods where there is little vehicle or pedestrian movement.

**Trimming** is the process of shortening the period for which the lamp is lighting. Modern lights achieve full light output quickly as distinct from older technologies which took a longer period to reach full output. LED lights generally use 35/18 photocells (turn-on when lux level drops to 35 and turn-off when Lux levels rise to 18. This results in a shorter burn hour annual calendar of 4,095 hrs/annum as against 4,150hrs/annum for the older SON/SOX type lanterns, which used 70/30 photocells.

A number of burn profiles have now been agreed with ESNB, UMR and Energy regulator and represent different tariffs to be charged on unmetered public lighting. These profiles are outlined in Appendix G.



## 2.6 UMR

The Unmetered Registrar (UMR), ESB Networks, Abbeyleix Road, Portlaoise, Co. Laois operates within ESB Networks and is responsible for overseeing the Market and DNO (distribution Network operator), Licence requirements pertaining to unmetered supplies (UMS).

Unmetered Public Lighting installations of less than 2kW (max usage on a single unmetered connection) are assigned a technical meter point registration number (TMPRN) by the UMR. TMPRNs are grouped under group meter point reference numbers (GMPRN) in the name of the relevant local authority. Billing takes place at the level of the GMPRN.

The asset owner is obliged to keep UMR's lighting database records for unmetered lights up to date. Public lighting generally uses unmetered tariffs as distinct from metered.

Based on annual burn hours (4,150 dusk to dawn or 2,600 dusk to midnight) the UMR calculates the billable wattage of every unmetered light and forwards this data monthly to the licensed energy suppliers so that the latter can bill their customers appropriately.

Lighting installations of greater than 2kW are required to be metered and are assigned a specific meter point reference number (MPRN) and each MPRN is billed monthly to the account holder.

TMPRNs and MPRNs, when advised by ESB Networks, must be registered with licensed electricity Energy Suppliers.

Certification of completed installations by a contractor registered with ECSSA or RECI must be provided to ESB Networks in order for installations to be energised.

***Cork County Councils preference is for unmetered tariff and larger developments can achieve this by using multi connection points to keep each connection below 2kW.***

## 2.7 EFFICACY (L90/B10)

Efficacy (lm/watt) is a measure of the efficiency of the light in terms of output per energy consumption. The higher the efficacy the lesser the wattage lantern required to achieve a required lumens output. It is calculated by dividing the lumen output by the wattage and multiplying by 90%, the other 10% being required for the internal operation of the luminaire itself.

***Cork County Council requires that all neutral white lanterns must have a minimum efficacy level of 140 lm/w and for neutral and a minimum of 130 lm/w for warm white, certified by a recognised accreditation body and measured within the complete lantern casing.***

Related to this is the relevant indicator as per EN 13201-5 :2015, the **Power Density Indicator** (PDI or  $D_p$ ) which is expressed in  $W.Lux^{-1}.m^2$

The other indicator is **Annual Energy Consumption Indicator** (AECI or  $D_e$ ) which is expressed in  $Wh.m^{-2}$ . The annual electricity consumption of a road lighting installation depends on:

- the period of time for which lighting is provided,
- the lighting class specified by the relevant lighting standard for each lighting period,
- the efficiency of the lighting installation, when providing the necessary lighting for each period,
- the way the lighting management system follows the change in visual needs of road users,
- the parasitic energy consumption of lighting devices during the period when the lighting is not needed.

## 2.8 COLOUR RENDERING

The **colour rendering index (Ra)** defines the ability of a light source to identify **colours**, and is measured on a scale of 1 – 100. . On this scale a **rendering** of 1 is monochromatic light, and a **rendering** of 100 is natural sunlight, so you can think of the scale as a measure of the quality of light produced by the source. LED’s have higher Ra values than traditional lighting.

LED Lanterns should have a colour rendering value of  $Ra \geq 70$ .

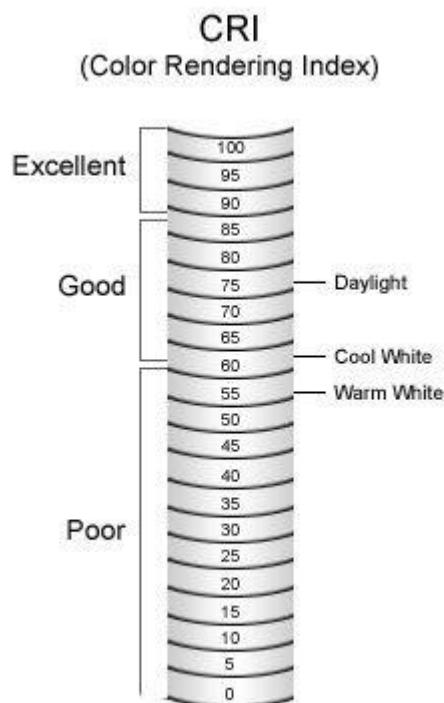

## 2.9 MAINTENANCE FACTOR

The maintenance factor is a number (positive and less than 1) used in calculations to account for the depreciation in light output over time.

## 2.10 LIGHTING CLASS

These are defined in BS5489 for residential (P Class) and traffic route lighting (M & C Class) situations.

## 2.11 UNIFORMITY

The relationship between the lowest maintained minimum illuminance (lux) value and the

average maintained value. Relates to both light intensity and luminance.

## 2.12 LUX

Illuminance is a measure of how much [luminous flux](#) is spread over a given area. One can think of luminous flux (measured in [lumens](#)) as a measure of the total "amount" of visible light present, and the illuminance as a measure of the intensity of illumination on a surface. A given amount of light will illuminate a surface more dimly if it is spread over a larger area, so illuminance (lux) is inversely proportional to area when the luminous flux (lumens) is held constant.

One lux is equal to one lumen per [square metre](#):

$$1 \text{ lx} = 1 \text{ lm/m}^2 = 1 \text{ cd}\cdot\text{sr/m}^2$$

A flux of 1000 lumens, concentrated into an area of one square metre, lights up that square metre with an illuminance of 1000 lux. However, the same 1000 lumens, spread out over ten square metres, produces a dimmer illuminance of only 100 lux. Below are some examples of the illuminance provided under various conditions:

Examples (source ILP GN 08/18)	
Illuminance	Surfaces illuminated by:
0.001- 0.0001 lux	Moonless, overcast night sky ( <a href="#">starlight</a> )
0.25 – < 1.0 lux	Full moon on a clear night
1 lux	Twilight
10,000- 30000 lux	Overcast day (Winter – Summer)
5 Lux	Typical road side lighting
5-20 Lux	Typical main road lighting
5,000 lux	Overcast day

32000–50000 lux	Typical Summers day
-----------------	---------------------



Light Meter

### **2.13 LUMINAIRE**

Complete (electric) lighting unit and all its related support and (non-network) supply equipment i.e. pole, bracket, lamp holder, ballast, reflector, control gear etc. as well as the actual bulb/lamp

### **2.14 PUBLIC LIGHTING UNIT**

Term used to describe the complete public lighting unit inclusive of luminaire, bracket and column.

### **2.15 LANTERN COMPONENTS**

The lantern components in an LED lantern comprise of the heat dissipation housing, the driver (electronic control unit), the lens, LED's and a photocell.

### **2.16 LANTERN FUSE**

The controlling fuse is located in the column base ,or in the case of overhead networks in the Pole mounted Isolation Box.

### **2.17 CIRCUIT FUSE**

Every lighting circuit must be protected by an appropriately rated fuse.

### **2.18 INTERFACE BOX**

This is a piece of electrical apparatus erected on ESB Network poles to segregate ESB Networks and the Local Authority electrical systems.

### **2.19 MINI-PILLAR**

These are ground mounted electrical distribution enclosures from which ESB Networks supplies emanate to Local Authority lighting pillars.

### **2.20 MOCROPILLAR**

These are ground mounted enclosures which receive electricity supplies for Public Lighting from ESB minipillars.

### **2.21 MIDIPILLAR**

These are larger sized pillars that can accommodate a surge protection unit, measuring 600mm wide x 300mm deep.

### **2.22 TMPRN**

Technical Metering Point Reference Number for a single or collection of luminaires, usually in a common location e.g. one street or avenue.

### **2.23 GMPRN**

Grouped Metering Point Reference Number = a group (one or more) of (loosely) spatially related TMPRNs e.g. the length of a national route in a county, a suburb of a city. Some Local Authorities have only one GMPRN for all lights under their control.

## **3.0 Objectives of Public Lighting**

### **3.1 Lighting Obstacles**

The main purpose of lighting in residential areas is to enable pedestrians to orientate themselves, to detect traffic and other hazards, and to discourage crime directed against people or property. Lighting of amenities such as walkways, cycle paths, playgrounds and monuments should be curtailed to dusk to midnight operation as against the normal dusk to dawn regime, unless there is a compelling reason to do otherwise, for energy conservation reasons.

### **3.2 Security**

An important purpose of lighting in housing estates is to create an environment in which the residents feel safe and secure. In areas where there is a high crime risk, care should be taken that any potentially dark areas are lit. More than one lighting unit at specific high-risk locations should be used so that a simple lamp failure does not leave an area in total darkness. Colour rendering is a help in crime detection and this should be taken into account when choosing a light source and colour temperature.

### **3.3 Pedestrian Safety**

Oncoming vehicles and bicycles must be easily recognised by pedestrians. It has to be possible for pedestrians to discern the features and intentions of a person who approaches them at night.

### **3.4 Road Safety**

The lighting on roads should provide guidance for motorists, but may be insufficient for revealing objects on the road without the use of headlights. Drivers must be able to distinguish pedestrians and oncoming vehicles.

### **3.5 Social Benefits**

Lighting should provide visual guidance for visitors who are not familiar with the area and who are looking for the homes of friends or relatives.

### **3.6 Avoidance of obtrusive Lighting – *Extracted from Guidance Notes for the Reduction of Obtrusive Light GN01:2021***

If possible, light should not enter the bedrooms of residents and the fitting of cowls or some other measure may be required where a resident complains of light pollution.

The ILP<sup>1</sup> brought out a useful guidance document in 2020, updated in 2021, on measures to be taken to mitigate light spill.

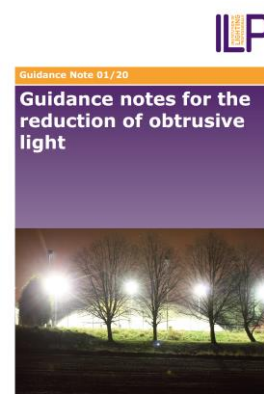

**‘Obtrusive Light**, whether it keeps you awake through a bedroom window, impedes your view of the night sky or adversely affects the performance of an adjacent lighting installation is a form of pollution. It may also be a nuisance in law and which can be substantially mitigated without detriment to the requirements of the task’.

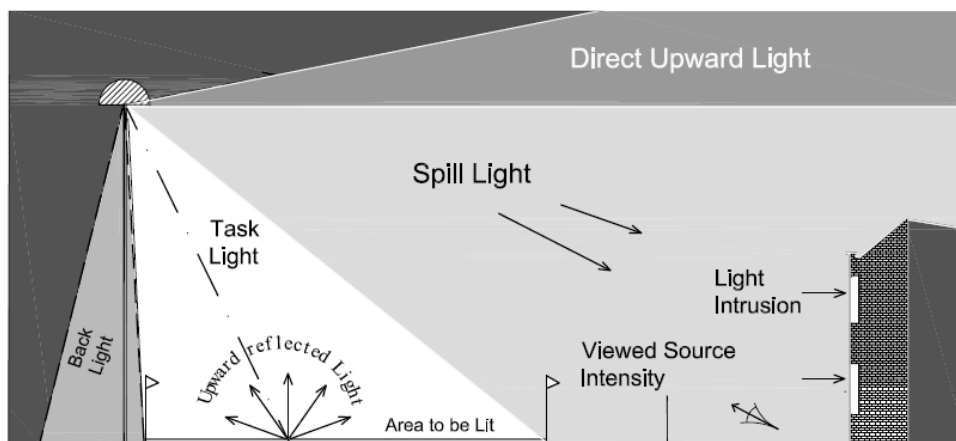

**Figure 1 – Types of obtrusive light**

Do not "over" light. This is a major cause of obtrusive light and is a waste of energy. There are published standards for most lighting tasks, adherence to which will help minimise upward reflected light.

The spill of light onto buildings opposite can be controlled by lessening the tilt angle or by using a narrow optic which limits the lateral spread. Manufacturers generally have a narrow, medium and wide optic options and also have optics which extend the light beam further or lesser in the longitudinal plane. **Generally, LED lanterns should be set in the range 0-5 degrees and the optic type should determine the lateral spread thereafter.**

### 3.7 ENVIRONMENTAL ZONES

DN-03038 Table 2 – Luminous Intensity Glass Req by Environmental Zone				
Zone	Surrounding	Lighting Environment	Examples	Intensity Classes
E0	Protected	Dark	UNESCO Starlight Reserves, Dark Sky	G6
E1	Natural	Intrinsically dark	National Parks, Areas of Natural Beauty etc	G5 or higher
E2	Rural	Low district brightness	Village or relatively dark suburban roads	G4 or higher
E3	Suburban	Medium district brightness	Small town centres or suburban locations	G3 or higher
E4	Urban	High district brightness	Town/city centres, high levels of night activity	G2 or higher

## **4.0 Types of Lighting Equipment**

This chapter contains the following:

- Types of Lamp's
- Typical lamp Wattage's
- Lanterns
- Switches & Control Gear
- Columns

### **4.1 Types of Lamps**

Historically the most common Types of lamps installed in residential areas and on traffic routes were high pressure sodium lights (SON), which replaced Low Pressure Sodium (SOX), and to a lesser degree Metal Halide (MH).

***Cork County Council's policy is now to only use low energy LED lighting on all new schemes/retrofits. Hence, new lights in both residential schemes and on new traffic routes shall be of LED type.***

The most commonly used lamps are described below:

#### **4.1.1 Light Emitting Diode Lamps (LED)**

LED lighting is the preferred technology for outdoor lighting based on the energy efficiency achievable compared to current HID technology and reflecting the need to accord with government energy reduction policy.

Colour Rendering (Ra) is of the same quality as for Metal Halide lamps and lifetime is projected to 50,000 to 100,000 hours or 12 years of dusk to dawn lighting.

LEDs can be acquired in cool (5000K), neutral (4000K) and warm (3000K) white.

#### **4.1.2 High Pressure Sodium Lamps (SON)**

High pressure sodium lamps were the most commonly used in street lighting. These lamps were developed in the early 1970's. Whilst they are marginally less efficient than SOX lamps they provided a much better quality of light in terms of colour rendering, making it possible to distinguish different colours though not to the extent with LEDs.

#### **4.1.3 Metal Halide Lamps (MH)**

Metal Halide lamps have a colour rendering (Ra) of 70 compared with an Ra of 20 for SON lamps. Consequently they are specified for urban commercial outdoor locations and remain the preferred light type for larger sports applications, but not for general use.



#### 4.1.4 Low Pressure Sodium Lamps (SOX)

These lamps which emitted a yellow/orange light with very poor colour rendering were historically installed extensively in residential areas (55 Watt) and on Traffic Routes (135 Watt). ***It is the intention that the remaining number of these type of inefficient lights will be phased out completely over the next few years.***



### 4.3 Switches & Control Gear

#### 4.3.1 Photocell

This system switches on the street light when the ambient light falls below a certain intensity and likewise switchoff when the light level resumes.

LED lights operate on the basis of 35/18 and they reach full output capacity instantly.

Photocells normally fail in the 'on' position enabling faulty photocells to be easily identified and replaced as the light will remain lit during daylight hours.

Photocells can operate individual lights, groups of lights or a whole scheme of lights. ***Cork County Council require individual photocells for each light.***

Photocells/timers can also be supplied to provide part night switching from dusk to midnight. This is especially useful to light recreational areas where it is unnecessary to keep these areas lit after midnight.

Photocells should be seven-prong twist lock NEMA socket or equivalent with a photo-electronic switch.

***Cork County Council do not favour mini-photocells which can be problematic. However, if there is no alternative, proposals should be submitted and will be considered on a case by case basis.***



Typical Photocell

### 4.3.2 Cables & Circuits

An appropriately rated circuit fuse should be used in the installation circuit.

For all new lighting installations, where the cable to the lights is no more than 3 x 6 sq. in size, then Type B MCB's are acceptable.

For all existing lighting circuits, even if retrofitting to LED, retain the Type C MCB's.

When the power supply is from underground and where dusk to dawn lighting is provided, an appropriately sized fuse should be provided in the base of each column.

Underground cables must be contained within 50mm (or 100mm for extended runs) red cable duct with appropriate markings and protected by cable marking tape, appropriately installed.

***Cork County Council favour 50mm ducting to run directly from light to light rather than offset except in exceptional circumstances agreed with the Public Lighting Engineer, so as to minimise the number of access chambers which require maintenance.***

## 4.4 Columns

### 4.4.1 Types of columns

- **Galvanised steel:** These can be of the root type mounted in sockets or flange type mounted on concrete foundations, fed through underground ducted cables. ***Cork County Council favour the use of rooted columns except in exceptional circumstances such as on bridge plinths or for high mast lighting.***
- **Aluminium:** These columns have the advantage of being light and easy to handle, and they give way in the event of an accident. These columns are quiet expensive. They are also less prone to corrosion and hence have a place for use in locations where seawater spray is likely to be present
- **Mid/Base Hinged:** Hinged columns should be used in areas of < 3.0 m road width which are inaccessible to maintenance vehicles. These allow the upper portion of the column to be lowered by hand to make the lantern accessible. Typical applications are amenity walks or narrow laneways.
- **Passively Safe:** Passively safe columns are specified in accordance with the requirements of BS 12767:2007. These are designed to yield in a safe manner when struck by a vehicle. ***Cork County Council's policy on the use of passively safe columns, on new schemes, is in accordance with TII protocol (TII Guidelines DN-LHT-03038) and hence in general, their use is required on roads with a speed limit > 80km/hr and at traffic calming gateways. TII require passive columns to be fitted with devices which disconnect the power supply immediately, once a passive column is struck.***



***Typical scheme of passively safe columns***

- **Decorative/Architectural:** Should be confined to town centre streetscape areas only and are still required to be manufactured to EN 40 series.

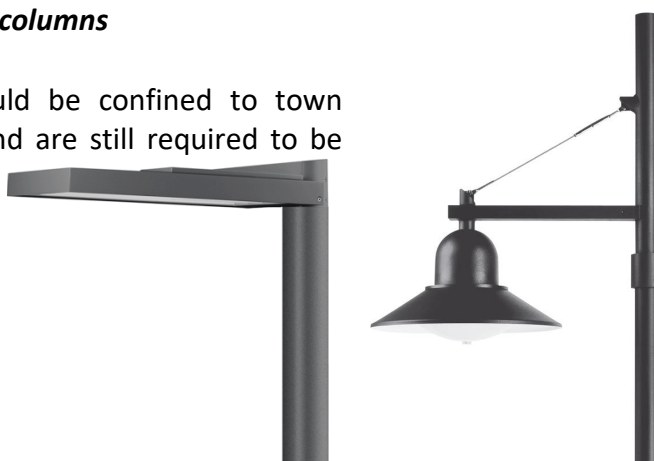

***In general, Cork County Council policy is to use underground ducted supplies and galvanised steel columns on new lighting schemes unless particular circumstances dictate otherwise.***

- **Cycleways/walkways:** Should be different to the norm and sleek and appealing with a slender matching column.



- **Traditional style:** In some instances in Town centres it may be appropriate to install traditional style lights and columns.



#### 4.4.2 Lamp fittings on Columns

Lamps can be installed on columns either directly post-top or on either an extended upright arm or with an outreach or combined extended outreach bracket. With LED Lights, post-top or vertical extension brackets are preferred, especially on ESB Network poles, as insisted upon by ESB Networks, due to the increased weight of LED lights over SON/SOX.

Outreach arms can be installed at tilt angles of 0, or 5 degrees to the horizontal. Tilt angles of 0 degrees should only be used on very narrow streets, as the light emitted by the lamp does not reach as wide an area as with larger tilt angles. ***Outreach arms should generally be avoided unless needed to extend the light across wide roads/dual carriageways.***

LED lanterns may be more suited to post top mounting and the lantern itself can be tilted to achieve an adequate design.

#### 4.4.3 Column Construction

Columns for public lighting should be manufactured from steel or aluminium alloy and certified to ISEN 40 Series. Columns are generally octagonal with a minimum wall thickness of 3mm. Steel columns and brackets should be hot-dip galvanised. Columns shall be coated outside with a protective coating to at least 150mm above planting depth. Such coating is usually applied to the bottom 1250 mm of the pole, but may be more for higher columns. Where columns are not erected at the same time as cables are laid, great care should be taken that an adequate loop of cable is left at the exact position of the proposed columns.

#### 4.4.4 Rooted/flanged

**Columns should generally be rooted but flanged types can otherwise be specified for particular locations.** Base details should be designed in accordance with the column manufacturer recommendation. Indicative minimum base dimensions are detailed in Appendix D, Fig. 13 a) & b), but foundations should be designed for specific site conditions.

#### 4.4.5 Mounting Heights

Typical mounting heights are 6m for residential and low volume subsidiary roads, 8m for Regional and Local Roads, 8m/10m for two way National routes with 12 m and higher for high-speed dual carriageways and motorways.

For cycleways & greenways 4m-6m mounting heights are acceptable.

In special situations where particular aesthetic or environmental factors apply, the use of other mounting heights might be more appropriate. (ref:-BS 5489-1:2013<sup>11</sup>)

#### 4.4.6 Lateral offsets

BS 5489-1:2013, Section 4.3.3.3, Table 2 provides guidance/standards for lateral offsetting of columns to ensure;

- a) that they are unlikely to be struck by wing mirrors of lorries/wide loads etc. and
- b) that the set-back should be sufficient to allow the free passage of all people on any footway.

**Cork County Council requires lighting to be located at the rear of the footpath, where one exists** or that the minimum offset outlined in Table 2 (of BS 5489-1:2013<sup>11</sup>, section 4.3.3.3 reproduced below), be observed in rural locations where a footpath is unlikely to be installed at any stage in the future. In urban locations where build-outs etc. allow the column to be located in an area which does not interfere with the footway a different location may be appropriate.

Under no circumstances must a column be located in the middle of a footway/cycleway, where it likely to be a hazard for pedestrians/cyclists/vulnerable road users.

extract from Table 2 – Recommended minimum clearances from edge of carriageway to face of column

Design Speed km/h	Minimum horizontal clearance (m)
<= 50	0.8
80	1.0
100	1.5
120	1.5

## **5.0 Public Lighting Design Criteria for New Schemes or Additional Lighting in Partly Completed Schemes**

### **5.1 Introduction**

The pattern of light emitted from a lantern is generally T shaped and of greatest intensity directly beneath the lantern. LED lights footprint varies with lens type and the appropriate profile should be chosen to suit the application.

The aim of public lighting design is to achieve uniform light spread over the area to be lit and to ensure that minimum levels (defined by the lighting class) are achieved throughout. Thereafter, the intention must be to ensure that lux contours merge satisfactorily along the length of the section to be lit and that at least the minimum lux contour level is achieved towards the extremities. Overlighting, well above the required standard is to be avoided and may be evident when examining a lux drawing where high intensity lighting levels are prolific.

This chapter outlines general lighting requirements and how these requirements can be met. Modern lighting design software enables the Designer to ensure that the lighting criteria are achieved in carriageways and footways.

#### **5.1.1 General Requirements**

***Cork County Council insist that all new designs/retrofits be designed by a competent professional using appropriate software. Lighting Reality is the current preferred lighting design package, which provides an appropriate report on the design inclusive of lighting class achieved, lantern types and a lux plan for the scheme.***

Designs shall be carried out to the appropriate latest BS & EN standards and the extracts following are merely samples for indicative purposes only.

The Design process should follow a logical procedure of;

- a) selecting the appropriate Lighting Design Class\* based on BS 5489-1:2013 *Code of Practice for the design of road lighting* by the selection of the appropriate Table from annex A, which guides the designer to the appropriate Table (A2 – A8) and
- b) applying the Environmental Zones factor i.e.

E0	‘Dark Skies Reserve’	
E1	Intrinsically Dark	Rural Area
E2	Low District Brightness	Town
E3	edium district brightness	Small town centres or suburban locations
E4	High District Brightness	City

*\*Alternatively, the appropriate Design Class may be selected by the process outlined in EN 13201-1:2014, Table 1 for M Class, Table 3 for C Class and Table 4 for P Class.*

c) apply the other factors which influence the design such as ‘maintenance factor’ etc. to determine the minimum maintained average & minimum Lux and the appropriate Uniformity required.

d) proceed to locate the columns appropriately and run the design through the software package, adjusting as appropriate until the design parameters are met using a particular lantern or combination of lanterns.

e) plot the lux levels and check that the minimum lighting level is achieved everywhere and that there is an appropriate level of overlapping, to avoid over-design.

***It is acknowledged that in a retrofit situation, where it is not feasible to install additional poles, that there needs to be some relaxation on some of the parameters such as the acceptance of a reduced level of uniformity, which still achieving a lighting standard at least equivalent to what is existing. The RMO Public Lighting Retrofitting Guidelines<sup>40</sup> should be consulted in relation to design of retrofit schemes.***

Colour temperature of LED lights determines whether they are classified as Cold, Neutral or Warm. The default colour temperature has migrated from neutral white to warm white in recent times, in line with other European countries. In line with this, ***Cork County Council’s policy on colour temperature is in line with other Counties and is outlined in the table below.***

<b>Location</b>	<b>Colour Temperature</b>
<b>National Road Network</b>	Follow TII Guidelines DN-LHT-03038 but generally warm <3300K, or neutral restricted to a maximum of 4000K
<b>Regional and local Roads, in general</b>	Warm White, 3,000-3,300K
<b>Large roundabouts and lights in the vicinity of zebra or uncontrolled crossings</b>	Neutral white, 4,000K, due to slightly better colour rendition in these significant conflict zones.
<b>Main St.’s of larger County Towns</b>	Neutral white, 4,000K, due to slightly better colour rendition in these conflict zones where pedestrians tend to cross the street, at will, but warm white can also be considered, where pedestrians cross at designated points.
<b>Smaller County Towns and Villages and sidestreets off Main St. in the larger Towns</b>	Warm White, 3,000-3,300K
<b>Residential Estates</b>	Warm White, (around 3,000K)
<b>Carparks</b>	Neutral White (4,000k) as white lights improves vision, and provides better facial recognition and reduces the fear of crime
<b>Around Historical Buildings, Old Town Centres</b>	Warm White (around 3000K), help enhance the historic character of buildings
<b>National parks, bat conservation areas</b>	Warm White (2700K) but should be considered on a case by case basis

Dimming and Trimming are methods used to save energy and carbon generation and should be incorporated in designs where feasible. Considerations range from;

- Road types and classification
- Road user types
- Activity levels in the area, especially after midnight, e.g. pubs/nightclubs, 24 hour facilities such as in the vicinity of Hospitals etc.
- The presence of Historical buildings and bridges
- The need for facial recognition and clear CCTV images
- Whether in Conservation Areas/ dark skies zones
- Areas where there is a high concentration of residents
- Risk of crime
- The need for good illumination for obstacles such as steps, bollards etc.
- Landscape areas such as parks, gardens, river walkways etc.

***Cork County Council's dimming and trimming policy is generally in line with other Counties and is outlined in general terms in the table below.***

<b>Location</b>	<b>Dimming/Trimming Profile</b>
<b>Motorway and Town Main St. where activity likely after midnight.</b>	*Profile U13, trimming only due to high volumes of traffic throughout the night or higher than normal volumes of pedestrians post midnight due to the presence of late opening bars/nightclubs. <i>However, consideration to be given to the use of 70/35 rather than 35/18 on Streets where where Pedestrians are likely to be crossing streets at random locations, at dusk/dawn times.</i>
<b>City/town centres, main roads</b>	Profile U14, considering reduced activity levels during the hours 12am and 6am with exceptions. <i>Again consider the need for 70/35 in place of 35/18 as above.</i>
<b>Residential Estates and rural residential settlements</b>	Profile U15 to reduce over lighting and light trespass during sleeping hours for designs above P4, ( <b><i>P4 designed schemes not dimmed to avoid light levels reducing below 1 Lux anywhere).</i></b>
<b>Carparks</b>	Profile U14 - sufficient lighting levels for staff up to 12:00 - sufficient illumination thereafter to deter criminal activity late at night.
<b>Park areas, pedestrian areas</b>	Profile U16 due to low traffic volumes and to deter antisocial behaviour between 12am and 6am. If the park is closed at night, consideration should be given to D2M or Profile U23 (old 4D), where anti-social-behaviour is likely.
<b>National parks, bat conservation areas</b>	D2M or multiple level dimming Profile U23 (old 4D) on a scheme by scheme basis

*\*The Profiles currently agreed with the ESB regulator/UMR are outlined in Appendix G.*



## 5.2 Lighting Requirements.

All Public Lighting must be designed to the appropriate Class and design parameters set out in the latest revisions of BS 5489 and EN 13201. ***Sample guideline figures are outlined in the following but should be treated as an approximation only in line with current Cork Co. Co. thinking but all designs in accordance with standards will be assessed.***

The generally accepted design class requirements for Public Lighting are set out in the tables below.

Lighting classes according to PD CEN/TR 13201-1:2014

Road Class	Description
M	For drivers of motorized vehicles on traffic routes medium to high driving speeds
C	For use in conflict areas on traffic routes where the traffic composition is mainly motorised. Conflict areas occur wherever vehicle streams intersect each other or run into areas frequented by pedestrians, cyclists, or other road users. Areas showing a change in road geometry, such as a reduced number of lanes or a reduced lane or carriageway width, are also regarded as conflict areas
P	For pedestrian traffic and cyclists for use on footways and cycleways, and drivers of motorised vehicles at low speed on residential roads, shoulder or parking lanes, and other road areas lying separately or along a carriageway of a traffic route or a residential road, etc.

***Cork County Councils preferences for new schemes are outlined in the table below;***

PL Design Class	Description
P2	Residential Distributor/ Main Spine road in large estate with relatively large traffic volumes.
P3/P4	Normal sized Residential estate main access road.
P4	Cul-de-sac branch roads within the estate.
C3	Main St. in a Town Centre
M4	Main St. in a Village

### 5.2.1 Lighting Requirements for housing estates, subsidiary roads and associated pedestrian areas.

There are six different P Classes defined in BS 5489. The most common are P2, P3 & P4.

Typical requirements are set out in Table A5 of BS 5489:2020, an extract from which is given in Table 5.2.1 below.

**Table 5.2.1 – Typical Housing Estate Lighting Classes**

Road Type	Lighting Class	Maintained Average Illuminance, lx LED	Maintained minimum illuminance, lx LED	Uniformity Emin/Eav
Roads where <ul style="list-style-type: none"> <li>- Night-time public use likely to be high</li> <li>- Or the crime risk likely to be high</li> <li>- Or the traffic usage is likely to be high</li> </ul>	P2	10.0	2.0	0.2
Roads where <ul style="list-style-type: none"> <li>- Public use is likely to be moderate</li> <li>- Or the crime risk is average to low</li> <li>- Or normal traffic usage is of a level equivalent to that of a housing estate access road.</li> </ul>	P3	7.5	1.5	0.2
Roads where <ul style="list-style-type: none"> <li>- Public use is likely to be moderate</li> <li>- Or the crime risk is average to low</li> <li>- Or quiet traffic usage is of a level equivalent to that of a residential road mainly associated with the adjacent properties.</li> </ul>	P4	5.0	1.0	0.2

***Lighting in housing estates in Cork County is generally to be designed to a minimum of P4 standard but P3 standard should be considered for the access spine road on larger estates.***

***Cork County Council require warm white light be used within Housing Estates.***

***Within a residential development, the requirement generally is to light the road, verge and footpath to at least the minimum level, as far as the adjacent boundary line of the properties. The lighting of recreational walkways through green areas and recreational/play areas is not a requirement but they may be lit if the applicant feels it is necessary or desirable, to the standards outlined in these guidelines. However, if the walkway also serves as a pedestrian/cycle access to/from the development, then they should be lit to the appropriate standard.***

***The design is required to be demonstrated, at planning stage, by the submission of a lux contour drawing, (1:500) showing contour lines at the maintained average level, the maintained minimum level and thereafter at lux intervals of 1.5, 3.0,5.0,10.0,15.0 etc.***

***The number of optics should be minimised for the particular schemes to assist future maintenance and the specific optic/lantern code should be identifiable on a label within the lantern. The brand type should remain the same throughout a confined development, in so far as practical.***

Conflict Class Design is only required on traffic routes and does not generally apply to junctions within housing estates, with the possible exception of the junction between the housing estate and the public roadway depending on traffic volumes.

## 5.2.2 Lighting Requirements for traffic route lighting design

### Lighting Classes for subsidiary roads with mainly slow moving vehicles, Cyclists and Pedestrians

Lighting classes for low speed subsidiary roads can be to the P-Classes. In luminaire retrofit situations up to the level of Regional Roads, where it is not possible to achieve full uniformity due to existing pole spacings, Cork County Council may accept P2 Class for such busier traffic routes. The parameters for this class are outlined below.

Road Type	Lighting Class	Maintained Average Illuminance, lx LED	Maintained minimum illuminance, lx LED	Uniformity Emin/Eav
Roads where <ul style="list-style-type: none"> <li>- Night-time public use likely to be high</li> <li>- Or the crime risk likely to be high</li> <li>- Or the traffic usage is likely to be high</li> </ul>	P2	10.0	2.0	0.2

### Lighting Classes for traffic routes shall be designed to M Class

Typical requirements are set out in in Tables A2 and A3 of BS 5489: 2020 and are selected from a range of 6 No. M & C Classes by reference to BS EN 13201-2: 2015, a sample of which are outlined in Table 5.2.2.

Road Type	Lighting Class	Lav in cd/m <sup>2</sup> (min maintained)	Maintained Average Illuminance (Lux)	Maintained minimum illuminance, lux	Uniformity
<b>Traffic Routes*</b>	M2/C2	1.5	20	8	0.4
	M3/C3	1.0	15	6	0.4
	M4/C4	0.75	10	4	0.4
	M5/C5	0.50	7.5	1.5	0.3
<b>Motorway</b>	M1/C1	2.0	30	12	0.4

**Table 5.2.2 – Typical Traffic Route Lighting Classes**

Conflict zones are designed to one class higher than the road Class. E.g. a road designed to M4 shall have a conflict class design of C3.

Traffic Route lighting on National Roads should be designed to TII Publications DN-LHT-03038 Aug 2018. Figure B.1, extracted below (from an earlier Revision) , is an indication only of the appropriate class for design.

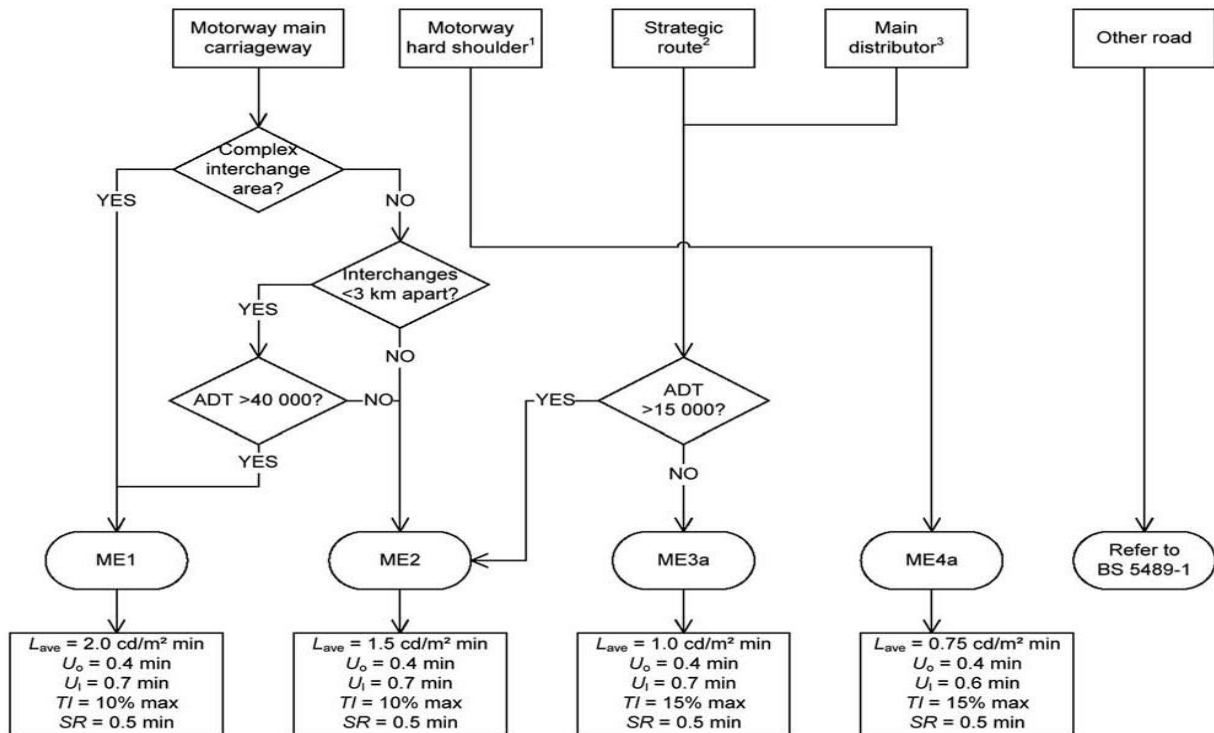

<sup>1</sup>Motorway hard shoulder: where not used as a running lane  
<sup>2</sup>Strategic route: Single or dual carriageway road carrying fast moving long distance traffic  
<sup>3</sup>Main distributor: Single or dual carriageway road between strategic routes and linking urban centres to the strategic network

DN-LHT-03038 Aug 2018 outlines it’s policy on luminaire temperature, to be used on National Roads in the following paragraph;-

The lighting designer shall consider the use of a warm CCT (<3,300K) or intermediate (limited to 4,000K) for the lighting design when using LED. Intermediate and cool temperatures (>4,000K) shall not be used.

**Conflict Class Design** is generally required, on traffic routes, at junctions, roundabouts, traffic calming gateways and town centre locations (where pedestrians are likely to be present). Where applicable the conflict class should generally be one class higher than the M Class. e.g. Design road generally to M3, conflict zones to C2.

### 5.2.3 Lighting Requirements for Traffic calming and pedestrian crossings

The lighting of Traffic calming gateways shall follow the principles outlined in Appendix F – Extract from TII Guidelines DN-LHT-03038 Aug 2018, which stipulates that traffic calming gateway central islands shall no longer be illuminated with a light within the central island. Instead a light on a passive column shall be located at either side with an optic suitable to illuminate the gateway signs.

All new zebra crossings shall incorporate additional targeted lighting over and above the general streetlighting, illuminated to both vertical and horizontal illuminance, which shall be designed in accordance with Technical Report 12 (TR 12). This standard aims to create a road beam of light, across the road, using optics which direct the light to the right/left as appropriate and which meet the standards required by TR 12 namely;

- The average horizontal illuminance on the crossing carpet shall be a minimum of 3.5 times that of the designed average horizontal illuminance of the standard road lighting appropriate to the lighting class chosen for the road.
- The uniformity within the above carpet would achieve a level of 0.6
- The vertical illuminance to be calculated on three vertical grids, each 1.5m high and the width of the crossing mat at a) centre of crossing, b) the kerb edge and c) rear of waiting area. Middle grid and kerb grid to be  $2.0 \times E_{av}$  and rear grid to be  $1.5 \times E_{av}$ .

## 5.2.4 Lighting Requirements for City and Town Centres

Requirements are set out in in Tables A6 of BS 5489: 2020 and are selected from a range of 4 No. C Classes and 2 No. P Classes by reference to BS EN 13201-2: 2015. C classes refer to conflict areas such as junctions or roundabouts etc.

**Table 5.2.4 – Typical Town Centre Lighting Classes**

Road Type	Lighting Class	Maintained Average Illuminance, lx	Maintained minimum Point illuminance, lx	Uniformity
Determined based on factors such as <ul style="list-style-type: none"> <li>- Night-time public use is likely to be high</li> <li>- Or the crime risk is likely to be high</li> <li>- Or the traffic usage is likely to be high</li> <li>- With mixed vehicle and pedestrians on separate footpaths.</li> </ul>	C2 (City/Town Centre with high traffic flows)	20	8	0.4
	C3 (Town Centre with normal traffic flows)	15	6	0.4
	M4 (Main St. in a Village)	10	4	0.4

For security and for visual guidance purposes the full street width building facade to building facade should receive at least the minimum level of light. In locations where a wide pedestrian area exists, a separate P Class may be more appropriate to apply to the footpath and in some cases, the addition of an additional light, at a lower level, to the rear of a column located on the roadside of the footpath, may be a more appropriate method of achieving adequate lighting on the footpath.

### 5.2.5 Lighting Requirements for Public Car Parks

Requirements for the lighting of Car parks are set out in Table 4 of BS 5489-1-2020. The requirements are measured in term of Eav and uniformity. ***In general Public Car Parks serving Towns would fall into the middle category in the following table;***

**Table 5.2.5 – Typical Lighting requirements for Car parks**

Car park Type	Maintained Average Illuminance lx	Uniformity U0
Light traffic, parking for shops, terraced and apartment houses, amenity car parks etc.	5	0.25
Medium Traffic, parking for department stores, office buildings, sports arenas etc.	10	0.25
Heavy Traffic, parking for schools, churches, major sports and building complexes	20	0.25

***Cork County Council’s policy is that dimming of Car parks should be incorporated into the design.***



### 5.2.6 Lighting Requirements for Recreational Areas (Town park walks/playgrounds/footbridges)

Requirements are set out in in Tables A5 of BS 5489-1: 2020 but *in view of the diverse nature of each particular site, no uniform method of lighting provision is suggested, and an individualized approach needs to be taken for each site. For this reason, only basic guidance is given with regard to the overall lighting provisions related to each area. This guidance is given in Annex A of BS 5489-1:2020.*

***Cork County Council's current policy is that unless otherwise justified, tariffs for recreational areas should be dusk to midnight and if necessary signs should be erected indicating that the lighting will go off at midnight.***

**Table 5.2.6 – Typical Recreational Area Lighting Classes**

Lighting classes for subsidiary roads with mainly slow moving vehicles, cycle paths and pedestrians paths (segregated).	Lighting Class	Maintained Average Illuminance, lx SON/LED	Maintained minimum Point illuminance, lx SON/LED
Recreational Areas	P4	5.0	1.0

Another option to be considered for recreational (off-road) walkways, is the use of low level lights ( 1-1.2m high) to light rural/coastal walkways, where tree cover or higher level light pollution is an issue. Spacings of about 15m seem optimal for these bolt down lights but would need to be established on a case by case basis by means of a Lighting design.



## 5.2.7 Lighting Requirements for Cycleways ( e.g.Greenways and off-road walkways)

Requirements are set out in in Tables A.5 of BS 5489-1: 2020 but ***Cork County Council are reluctant to go below Class P3 for this category giving the hazard presented from fast moving cyclists conflicting with slow moving pedestrians on a shared surface. Likewise cyclists travelling in opposite directions. This stance is in line with the recommendations of ILP TR23 – Lighting of cycle tracks.***

Consideration should also be given to designing to an appropriate EV Lighting Class using vertical illuminance when there are particular concerns about crime and personal safety. EV Class aims to illuminate a persons’s face at a height of 1.5m in relevant viewing orientations.

**Table 5.2.6 – Typical Cycleway/off road walkway Lighting Classes**

Lighting classes for subsidiary roads with mainly slow moving vehicles, cycle paths and pedestrians paths (segregated).	Lighting Class	Maintained Average Illuminance, lx	Maintained minimum Point illuminance, lx	Uniformity
Cycleways/walkways	P3	7.5	1.5	0.2
Walkways	P4	5.0	1.0	0.2

***Segregated, (cycle portion clearly delineated from pedestrian portion) off-road walkways could be considered at P4.***

***In certain circumstances, where demonstrated to be feasible, the alternative of a solar powered lighting scheme could be considered in such circumstances. This alternative cannot really be considered for roadways as passing traffic, detected by the PIR would cause the energy to be drained more quickly than in an off-road situation except perhaps, a footpath along a rural road, with very low traffic volumes.***



***Typical cycleway lighting***



***Typical walkway lighting***

## 5.2.8 Lighting Requirements for Steps, Stairs, Ramps and Footbridges.

Special care and attention should be given to the illumination of steps/stairs and ramps. These should be lit from below so that a person descending is not shadowing the light onto the next step. **Light units built into walls or low level bollards are to be avoided, in so far as possible, due to maintenance /vandalism issues.**

Lighting of a footbridge can either be by columns or inbuilt in the railing.

**Table 3** — *Maintained lighting levels for subways, footbridges, stairways and ramps*

Type	Values in lux			
	Day		Night <sup>A)</sup>	
	$\bar{E}$	$E_{\min}$	$\bar{E}$	$E_{\min}$
Subways				
• open <sup>B)</sup>	—	—	20	10
• enclosed <sup>C)</sup>	350	150	20	10
Footbridges				
• open <sup>B)</sup>	—	—	20	10
• enclosed <sup>C)</sup>	350	150	20	10
Stairways/ramps				
• open <sup>B)</sup>	—	—	20	10
• enclosed <sup>C)</sup>	350	150	20	10

<sup>A)</sup> The night time levels should be lit in proportion to the approach lighting, i.e. not more than 2 classes higher and not lower than the actual levels of the approach lighting.

<sup>B)</sup> “Open” equates to major daylight penetration.

<sup>C)</sup> For “enclosed” areas emergency lighting might be needed. It is essential that it is installed if the area forms part of an escape route from a shopping centre, car park or transport interchange.

### 5.2.9 Lighting Design for Canals, Locks, Piers and Harbours.

Piers and Harbours require a high level of lighting due to significant hazards that are associated with the location and the type of work, loading and unloading etc.

The table below is from **BS EN 12464-2:2014** Light and lighting — Lighting of work places Part 2: Outdoor work places

Table 5.4 — Canals, locks and harbours

Ref. no.	Type of area, task or activity	$\bar{E}_m$ lx	$U_o$	$R_{GL}$	$R_a$	Specific requirem
5.4.1	Waiting quays at canals and locks	10	0,25	50	20	
5.4.2	Gangways and passages exclusively for pedestrians	10	0,25	50	20	
5.4.3	Lock control and ballasting areas	20	0,25	55	20	
5.4.4	Cargo handling, loading and unloading	30	0,25	55	20	For reading labels: $\bar{E}_m = 50$ lx
5.4.5	Passenger areas in passenger harbours	50	0,40	50	20	
5.4.6	Coupling of hoses, pipes and ropes	50	0,40	50	20	
5.4.7	Dangerous part of walkways and driveways	50	0,40	45	20	

### 5.2.10 Lighting Design of Sports lighting (floodlighting)

Lighting Design for floodlighting of Sports fields shall be in accordance with BS EN 12193:2018 (incorporating corrigendum – February 19) *Light and lighting – Sports Lighting* or any further update of this standard and EN 13201:2015.

In particular, the Designers shall demonstrate that they have complied with the limits imposed by **Table 2 – Maximum direct obtrusive light permitted for exterior lighting installations** for the appropriate Environmental zone applicable to the Area. Designer is also required to demonstrate compliance with **Table 3 – Maximum values of threshold increment from sports lighting** installation in circumstances where a public road(s) is likely to be affected by the glare from the floodlights for the appropriate lighting class applicable to the road(s).

Demonstration of compliance with Table 2 can be achieved by providing

- a) A plot of lux contours showing the extent of spread of Horizontal illuminance ( $E_h$ ) relative to nearby dwellings and
- b) A plot of Vertical Illuminance ( $E_v$ ) levels on the walls of adjacent dwellings and indicative Building Luminance levels, taking account of any ground level differences, as outlined in more detail in Chapter 19.
- c) If levels are unavoidable exceeded, the Designer should outline the mitigating measures proposed to bring the levels below the limits outlined in Table 2 through the use of cowls, hoods, louvres, shields or whatever, by showing the values before/after the application of the mitigating measures.
- d) Designers should also indicate the intended latest time that the floodlights will be used as a curfew may need to apply for the sake of adjacent residents or for ecological reasons etc.
- e) Demonstration of compliance with Table 3 can be achieved by demonstrating that the threshold increment from the sports lighting does not exceed the values in Table 3, for the appropriate road lighting design class, at points along the roadway from where the floodlighting is likely to be visible and the cause of glare. This can be demonstrated through Lighting Reality by creating an Illuminance Glare report and map as outlined in more detail in Chapter 19.

### 5.2.11 Maintenance factor for Design

A **maintenance factor** based on a cleaning cycle of six years shall be incorporated into the design. ***In the event that this information is not available from the lamp and / or luminaire manufacturer(s) a maintenance factor of 0.76 shall apply to columns < 6m high and 0.84 to columns > 6m high*** in an E3/E4 environment. (For LED's the basis for the selection of the maintenance factor should be indicated).

The lamp flux maintenance factor can be established from the lamp manufacturer's data, and typical luminaire maintenance factors are given in BS 5489–1: 2020 Table C.1 of Appendix C (informative).

Consideration will be given to manufacturer's data regarding maintenance factors for conventional LEDs.

### 5.2.12 General

Design submissions for all new schemes should include the isolux contours on a map to demonstrate that the required Class has been achieved throughout and shall be accompanied by a lighting design report indicating that the minimum lighting class requirements have been achieved. ***The isolux contours should extend to the modelling of existing adjacent lights to ensure that both systems mesh together to give continuous lighting to the required standard.*** A Design report and schedule of proposed lights should also be submitted. The Design report should contain details of the light proposed to be used within the development.

***Cork County Council requires that all neutral white lanterns must have a minimum efficacy level of 140 lm/w and for neutral and a minimum of 130 lm/w for warm white, certified by a recognised accreditation body and measured within the complete lantern casing.***

Further details of the minimum standard of lantern/luminaire are outlined in Chapter 7. ***The wattage of the light shall be stated as that associated with constant light output over the expected lifetime of the fitting.***

### 5.2.13 Dimming and Trimming

LED lights, by their nature, lend themselves to trimming as they reach full potential very quickly when compared to conventional lights. A number of burn profiles, incorporating trimming to 35/18, have been agreed between ESB and CCMA/SEAI.

These burn profiles allow for dimming to different percentages. Examples are profiles, U14, U15 & U16 which are currently available for use and should be incorporated into the design where appropriate. Each profile involves the dimming of lights between 12 midnight and 6 am to different extents, (75%, 67% and 50% respectively) to correspond with one lighting class drop per profile change.

***Cork County Council policy is to incorporate factory set dimming to the next lower Lighting Class between 24.00hrs. and 06.00hrs in non post midnight activity locations but subject to an absolute minimum level of 1.0 lux.***

Locations where post midnight activity is likely would be the likes of roads/ streets with night clubs, hospitals, train stations, port facilities etc.

***LED Lighting shall have a 35Lux on/18Lux off dusk to dawn photocell controlled switching regime on roads and 35 lux on to midnight off on amenity walks/playgrounds/monument lighting etc.***

***The exception to this rule would be at Zebra Crossings points where 70/35 is preferred on road safety grounds and consideration should be given to using the 70/35 photocell where pedestrians are crossing randomly on streets or at uncontrolled crossing points.***

## 5.3 Light Spacing, Arrangements and Tilt Angle

### 5.3.1 Spacing

All lighting should be designed by a competent Public Lighting Designer using specialised software. The following rules of thumb are indicative of design outputs and should be used only for initial estimates.

**Straight roads:** In residential schemes with a straight 6m wide roadway with a 2m footpath on either side, the minimum standard of illuminance considered acceptable can be provided by the installation of lights at 30-35m spacings with 6m mounting height and either none or 0.5 meter outreach arm.

**Bends and Junctions:** At bends and junctions, the distance between two adjacent poles should be considerably shorter than the above recommended value for straight roads. In bends, the poles should be located on the outer side of the bend. The sharper the curve, the closer the poles should be to each other.

**T-Junctions:** It is recommended that a light be placed on the main road, opposite the centreline of the minor road. The distance between the pole at the junction and first pole on the minor road should be less than half the distance between two adjacent poles in places where there is no junction.

**Lantern Optics** provide options to suit different road widths or pattern requirements to fit various scenarios. Typical lighting distribution patterns achievable are outlined below.

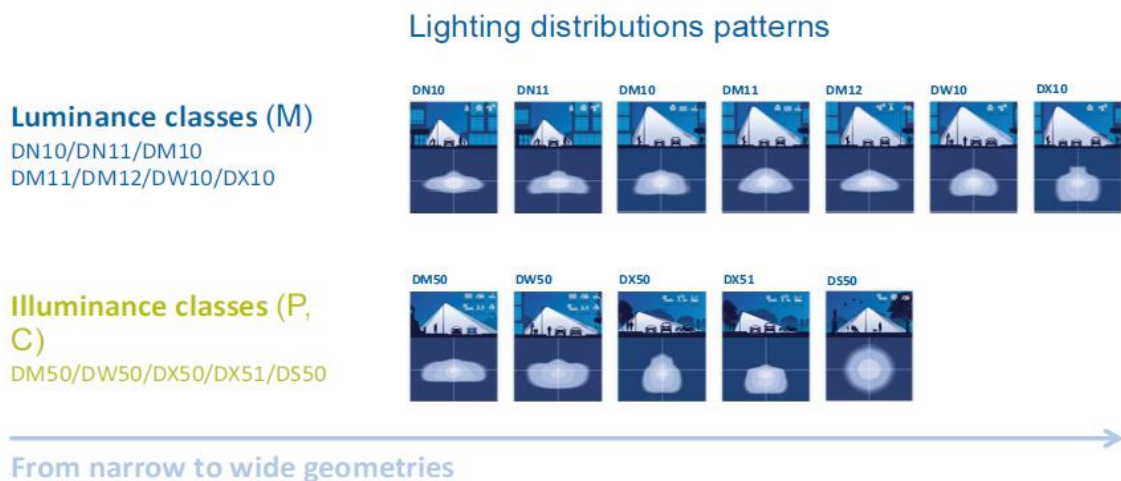



### 5.3.2 Arrangements

**Single Sided:** In a single sided arrangement, all the lights are located along the same side of the road.

**Opposite:** The lights are placed opposite each other on both sides of the road, resulting in good longitudinal luminance along the length of the road.

**Staggered:** the lights are placed alternately on both sides of the road in a zigzag pattern. The spacing between two poles may be increased when this arrangement is used, but the longitudinal luminance along the road will be low.

### 5.3.3 Tilt Angle

The outreach arm can be installed at tilt angles of either 0 or 5 degrees. A 0 degree tilt will allow the lamp emit light only to a small area of road just below the lamp. A tilt angle of 5 degrees is generally recommended.

***Cork County Council favour post top rather than outreach on new LED installations.***

### 5.4 Lights Fixed to Buildings

Public Lights can be fixed to buildings, usually in streets where space is limited. The permission of the building owner and that of ESNB is required before lights can be attached to buildings. A wayleave agreement should be signed by the consenting owner to ensure continuity in the event of future transfer of ownership of the property.



## **5.5 Lighting of steps**

Steps should be illuminated from the bottom up to highlight the step edges. i.e. the lighting columns should be located at the bottom of the steps where possible and practicable. In some cases it may also be necessary to erect columns within landings at intervals on long staircases. It may also be possible to build lighting units into walls but these can be subject to vandalism.

## **5.6 Lighting of pedestrian bridges**

Overhead lighting from columns designed to fit within the structure of the footbridge are the preferred option but continuous lighting built into the base of the handrail is also an option provided it can be demonstrated to meet appropriate standards.

## **5.7 Verification of Designs**

Light Measurement to verify the lighting levels achieved should be carried out on new schemes on a sample basis. The ILP Technical Report 28 Measurement of Road Lighting Performance on site; is a simplified methodology for assessing the street lighting performance on the streets. This report has been widely accepted as a robust approach for Maintenance Contracts. The ILP report adopts a proven yet simplified process that records some 15 points on the road and verifies the design has been installed correctly or otherwise.

## **6.0 Installation Procedures**

### **6.1 Connection Arrangements**

#### **6.1.1 Overhead Mains Cable**

Where mains cables are overhead- carried on ESB Networks Ltd. wood or steel poles – it has been normal practice to provide street lighting from lanterns mounted on brackets fixed on these poles. As these brackets are always close to live ESB networks, only duly qualified persons, authorised by the Local Authority are permitted to install or work on this type of installation. Since 2010 ESB has discouraged the erection of new assets on its Network Poles and ***hence a ducted underground supply feeding stand-alone public lighting columns is the preferred option for new installations.***

An interface box is required for new or replacement lanterns or brackets erected on ESB Network poles. . Ref. ESB Requirements for Work on Public Lighting on ESB's Networks 2020. A typical interface box is illustrated in Appendix D, Figure 9.

#### **6.1.2 Underground Mains Cable**

Underground mains cables are to be laid in accordance with ET210: 2003 Code of Practice for Public Lighting Installations in Residential Areas. A separate underground cable is required to be used exclusively for public lighting supply. This cable shall be installed in a duct (generally 50mm red duct) in accordance with the requirements of I.S. 10101:2020 or as per scheme design as appropriate.

It is essential that public lighting columns should be erected at the same time or very shortly after the cable is laid. Where columns are not erected at the same time as cables are laid, great care should be taken that an adequate loop of cable is left at the exact positions of the proposed columns and does not constitute a tripping hazard.

At this stage, the cable is particularly susceptible to damage by machinery and builders' equipment. It is strongly recommended therefore, that the loops be clearly marked and enclosed in a short concrete pipe or other similar protection which will draw attention to the presence of the cable.

It is also advisable to liaise with ESB Networks with regards to agreeing suitable supply points, at an early stage in the planning/design process.

Underground fed lighting schemes are required to have an interface with the ESB network supply. This usually takes the form of a midi/micro pillar, with adequate earthing.

## 6.2 Installation Procedures for Columns

### 6.2.1 Foundations for columns

Columns should be erected in the following ways:

- **Rooted** : A concrete or corrugated PVC pipe of approximately 300mm diameter (column height dependent, see table of sizes in typical details in Appendix D), is installed in a foundation excavation and then surrounded by concrete prior to the erection of columns. The root depth and extent of concrete surround is dictated by the column height and ground conditions. When the base has set, the cable is threaded through the column, which is stood vertically and the gap between the column and the sleeve is filled with compacted gravel or sharp sand (facilitating drainage and soakage) and capped with a sand/cement mortar with sloping surface within a short time, ( to avoid waterlogging of sand). Typical details are given in Appendix D, Fig. 13.(a).
- **Flanged**: A concrete base is laid and a flange type column is used. Holding down J-bolts are incorporated into an in-situ concrete base and a flange type column is subsequently erected and secured by nuts. The size of the base varies with size of column. Ref. BS EN 40-3-1/3 and PD6547>:2004 and Appendix D. Fig. 13.(b). The concrete used in this foundation type must be construction grade using concrete of strength at least 30N/20, laid and vibrated in a form and given an opportunity to attain design strength before the column is attached.

***Cork County Council favour rooted columns generally, unless there is a specific reason for using flanged.***

***All columns in housing areas should be erected at the back of the footpath on public ground, (i.e. not on private property). It should follow logical routes and not simply the shortest distance.***

For traffic routes columns should be erected at an offset as specified in BS 5489 (paragraph 4.3.3.3, Table 2) for Traffic Routes.

***The set-back of lighting columns should be sufficient to allow the free passage of all people on any footway. Columns should never be located within likely pedestrian/cycle pathways where an unsuspecting person would be at risk of inadvertently colliding with the column.***

***Landscape designs need to take cognizance of public lighting layout and vice versa. Trees/shrubs/hedges should not be planted in locations where they are likely to interfere with the required spread of light from public lights and with access for maintenance, over time.***

***Ideally, tree planting should be located at the opposite side of the road to the lights and the expected upper/lower level of the foliage (determined by choice of tree type) should be such as would not interfere with the expected light distribution pattern, either laterally***

***or longitudinally. Trees should never be planted longitudinally, within 10m of a lighting column, on the same side of the road.***

Columns should have a double locked framed door and should be galvanised. Doors should allow the Operator to face oncoming traffic, when working on the column and the door plane should be perpendicular to the road edge.

It is common practice to reduce column spacings on a bend by 10%.

### **6.3 Provision of Ducting.**

Excavation and backfilling of roads/verges etc. for ducting shall be carried out in accordance with DTTAS Guidelines for Managing Openings in Public Roads Second Edition, April 2017<sup>38</sup> (or latest version). Openings on public roads, in the charge of the Council, require a licence from the local authority.

#### **6.3.1 Standards of Ducting**

Ducting should be made of PVC to IS135 Class B having a minimum 50mm diameter for public lighting cable and 50mm/100mm diameter for ESB network supply distribution cable to lighting pillar. Ref I.S. 10101:2020.

Ducting shall be red coloured and have the words “Street Lighting” stamped on it in 9mm high lettering at 1m intervals, with the lettering labels facing upwards in the trench. Ducting for street lighting should be located relative to other services as indicated in Figure 4 and 5, Appendix D. Warning tape must always be used.

#### **6.3.2 Ducting in Verges/Footpaths**

Ducting should be laid in a bed and surround of Clause 503 material at a minimum depth of cover as specified in ‘Managing Openings in Public Roads Second Edition, April 2017 (or latest version of what is commonly referred to as ‘the purple book’). Warning marker tape shall be laid in the trench at an appropriate level above the duct. Ducts should be installed complete with 6mm diameter polypropylene rope for subsequent pulling of supply cable. The ESB require that a 6mm diameter rope be provided to draw-in their connecting cable to lighting pillars from supply distribution points.

#### **6.3.3 Ducts under Roads**

Ducts laid in roads should be adequately protected by a cover of cement bound material as outlined in ‘the purple book’. Road crossing ducts should generally be 50/100mm diameter and may require a junction box either side for future replacement of cables. The duct ends shall be protected from ingress of rubble or other material. Cross road ducts should extend a minimum of 300mm into the grass margin beyond the edge of the hard shoulder or kerb and should end in a chamber either side of the road. In simple cases, where the duct is just the continuation of a run of lights, the 50mm duct may suffice.

### 6.3.4 Ducting Surround

The compacted thickness of CI 503 material above and below the duct should be a minimum of 50mm. The remainder of the trench should be backfilled to ground level using imported compacted crushed stone or as specified in the *Guidelines for Managing Openings in Public Roads* and any Road opening license special conditions.

### 6.3.5 Ducting Arrangements

Cork County Council favours ducting layed column to column and micro/midi-pillar to column. However, no more than about 9 lights/300m max (in either direction from a micro/midi-pillar) should be attached to one circuit, due to voltage drop in the long cable. Where strings are to be > 9 lights/300m, an additional micro/midi-pillar is required with a direct feed either from ESB source or from the first micro/midi-pillar. The duct between such points may need to be 100mm+ as dictated by the wiring design.

Schemes in significant conflict zones should be designed such that if a circuit fails, every second light will still be working. This may be achieved by laying a 100mm duct independent of the lights and tee-ing off to every second light with a cable from alternate circuits. Such an arrangement is favoured for Town Centre locations and on new National Route schemes.

Ducting setback in relation to road edge will vary depending on the setback of foundation blocks and/or rooted lighting columns. In general, the ducting should either run directly from column to column or alternatively 500mm in front of the block/column positions, with a minimum 150mm between centre of duct and front face of foundation block or root type column.

Cables should be fed from supply ducts to foundation block duct opening or cable slots of root column, both in and out, to project into column at least 300mm above top of cable slot. In the case of flange plate columns, a 90 degree long radius bend should be fixed within the foundation block and should be sufficiently long to project 100mm above top of block. Reference Fig. 10 Appendix D. ***The coupling should be such that the cabling can be easily withdrawn at some future stage, in case of replacement need.***

In residential schemes direct coupling from column to column in 50mm duct is preferred to by-pass ducting with Tees.

All duct runs should be marked with electrical marking tape at a level of 350mm below finished ground level or as outlined in the *Guidelines for Managing Openings in Public Roads*.

### 6.3.6 Manhole Chambers

In general manhole chambers are not required or desirable except in complex situations or where ducting is not laid, column to column. Junction boxes may be required at sharp T-junctions or sharp changes in direction or intermittently, where long cable runs are proposed and such chambers are required for pulling of the cable. Where required, such chambers should be of adequate construction to withstand a vehicle on the verge/footpath and with covers of adequate strength. Further detail on manhole chambers is outlined in Chapter 11.

### 6.3.7 Time Schedule

It is recommended that ducting be laid as late as possible in the road construction programme, just prior to footpath construction or final landscaping if possible, in order to minimise exposure to damage by other operations.

**Note: All ducts shall be proven, with brush and mandrill, polypropylene roped and plugged, and compliant with the Irish ET: 10101 requirements that red ducts be used for exterior lighting cables.**

### 6.4 Customer Service Pillars

Customer Service Pillars (Exterior Lighting Micro/Midi-Pillars) shall be installed in all new installations fed by underground cabling. They shall be positioned a minimum of 2m apart from ESB mini-pillars or other supply source, (ESB pole etc.) as illustrated in Appendix D, Figure 6. If this is not physically possible and only with the explicit permission of ESB Networks and Cork County Council Public Lighting Division these may be installed closer together and equipotentially bonded in accordance with IS: 10101.

**In all cases it is not acceptable to utilise the same chamber to service both an ESB Networks (DSO) Mini-Pillar and Customer Service Pillar (Micro/midi-Pillar).** If this is found to be the case ESB Networks will refuse to connect the Customer Service Pillar and Cork County Council will not be in a position to take the Scheme in charge.

Likewise, public lighting micrio-pillars cannot be used as connection points for other than public lighting. For example, separate lighting pillars are required when the public lighting is installed in conjunction with an unmetred pedestrian crossing.

### 6.5 Earthing requirements for a midi/micro pillar

- The minimum earthing requirements for a micro/midi-pillar are of the order of 4m long x 25mm cable earthed in a trench.

NOTE:

**In certain locations with very poor earthing conditions, an additional earthing system may be required to be installed for public safety. This may require extra trenching or installation of additional earth rods etc.**

Earthing systems are vital for public safety.

## **7.0 General Technical Specification for Luminaries**

Cork County Council requires that the following general specifications be followed in the design and installation of exterior lighting schemes in Cork County.

- 7.1 Luminaires shall be LEDs** and shall comply with I.S. EN 60598-2-3 and IEC 62722-2-1 Luminaire Performance – Part 2-1: Particular requirements for LED luminaires and the specification outlined further along in this Chapter.
- 7.2** All new luminaires shall incorporate **electronic control gear** and a photocell in each lantern as standard.
- 7.3 Decorative, architectural** or period style lanterns shall be LED.



- 7.4** All **photocells** should be manufactured to accord with BS 5972 and have a 35/18 Lux switching on LED lanterns.
- 7.5** All overground luminaires shall be **sealed to the appropriate rating** and shall incorporate ingress protection to a minimum of IP65 for the lamp enclosure in locations other than sea-wall areas where IP 66 is required. All underground luminaires shall be sealed to IP67.
- 7.6** All non-LED luminaires shall have a **polycarbonate or toughened safety-glass lens** or approved similar. In any event the proposed luminaire shall have a minimum impact resistance rating of IK08 or greater as defined by EN 50102. This is to ensure a suitable level of robustness of the lens / bowl to vandalism. Most good quality luminaires meet this requirement, however Cork County Council reserve the right to receive confirmation of this from the manufacturer.



**7.7 Cork County Council Maintenance obligations, aim to keep the number of diverse luminaire models within reasonable limits in its inventory. (Cork County Council's Public Lighting Department can advise on this, ([publiclighting@corkcoco.ie](mailto:publiclighting@corkcoco.ie) or 022-54802) Lanterns shall comply with the appropriate standards BSEN60598 and IEC62722-2-1: 2014 and only recognisable brands, for which spare parts will be readily available for many years to come, will be accepted.**

This is to allow economies of scale to be achieved in the maintenance (replacement, spares etc.) of its exterior lighting assets.

Cork County Council may seek validation of certificates by an independent accreditation body. ***New or unusual brands may be considered where they are certified to be in accordance with aforementioned standards but evidence of this certification and component quality will have to be issued to the public lighting engineer for approval before incorporation into the design. In the main such diverse brands should be avoided except perhaps in the case of decorative lanterns.***

## 7.8 LED Lantern Specification

***LED Lanterns which are to be taken in charge by Cork County Council shall be commonly used reliable brands & shall comply with the following requirements:***

The LED luminaires and drivers shall comply with the following standards. As well as complying with the current requirements of IS EN 60598-2-3, the luminaires and components shall also comply with the requirements of the current edition of the following standards or equivalent where relevant:

### Luminaire and driver standards

Standard	Title
<b>General</b>	
IEC 62504:2014+ A1:2018	General lighting - Light emitting diode (LED) products and related equipment - Terms and definitions
<b>Product electrical safety standards</b>	
EN 60598-1:2015+A1:2018 Luminaires – Part 1: General requirements and tests	EN 60598-1:2015+A1:2018 Luminaires – Part 1: General requirements and tests
EN 60598-2-3:2003+A1:2011	EN 60598-2-3:2003+A1:2011
EN 60838-1:2017+A1:2017	Miscellaneous lamp-holders. Particular requirements. Connectors for LED modules
EN 62031:2008 + A2:2015	LED modules for general lighting. Safety specification.
IEC 61347-2-13: 2014+ A1:2017	Lamp controlgear: Particular requirements for d.c. or a.c. supplied electronic controlgear for LED modules
<b>Photobiological safety standards</b>	
EN 62471:2008	Photobiological safety of lamps and lamp systems
<b>Electromagnetic compatibility</b>	

EN 55015:2013+ A1:2015	Limits and method of measurement of radio disturbance characteristics of electrical lighting and similar equipment
EN 61547:2009 COR 2015	Equipment for general lighting purposes. EMC immunity requirements
<b>Product performance standards</b>	
EN 62384:2006 + A1: 2009	DC or AC supplied electronic control gear for LED modules. Performance requirements
EN 62386 101:2014/AMD1:2018	Digital Addressable Lighting Interface. General requirements: System
EN 62386-102:2014/AMD1:2018	Digital Addressable Lighting Interface. General requirements: Control gear
EN 62386 103:2014/AMD1:2018	Digital Addressable Lighting Interface. General requirements: Control devices
EN 62386-207:2018	Digital Addressable Lighting Interface. Particular requirements for control gear. LED modules (Device type 6)
EN 62707-1:2013+A1:2018	LED. Binning. Part 1. General requirements and white grid
EN 62717:2017 +A2:2019	LED modules for general lighting. Performance requirements
EN 62722-2-1:2016	Luminaire performance. Particular requirements for LED luminaires
EN 61643-11:2012 + A11:2018	Low-Voltage Surge Protective Devices - Part 11: Surge protective devices connected to low-voltage power systems - requirements and test methods
IEC 62262:2002	Degrees of protection provided by enclosures for electrical equipment against external mechanical impacts (IK code)
IEC TR 62696:2011	Luminaires - Application of the IK code IEC 62262

## Luminaires – Body and General

1. The lanterns shall be tested and approved by an independent 3rd Party ENEC (European Norms Electrical Certification) national Certification Body and awarded the ENEC mark in accordance with CENELEC Operational Document CIG 021 & evidence of same to be provided.
2. The manufacturer shall be accredited to the following standard:
  - a. BS EN IEC/ISO 17025, General requirements for the competence of testing and calibration laboratories, BS EN ISO 9001, Quality management systems, Requirements with guidance for use, BS EN ISO 14001, Environmental management systems.
3. Lanterns shall be designed for LED light sources only. Lanterns originally designed to be used with conventional light sources and subsequently modified or updated to accommodate LED light sources will not be accepted.
4. The lantern shall be fully compliant with all relevant European/British standards and EC Directives as required to demonstrate full compliance with the CE Directive and be clearly marked accordingly. Certificates of compliance for all lanterns shall be submitted.
5. Luminaires shall be supplied completely assembled and ready for use.
6. The lanterns shall be designed, manufactured and tested in accordance with the essential requirements of:
  - a. BS EN 61000-3-2, Electromagnetic compatibility (EMC). Limits. Limits for harmonic current emissions. (equipment input current  $\leq 16$  A per phase)
  - b. BS EN 61000-3-3, Electromagnetic compatibility (EMC). Limits. Limitation of voltage changes, voltage fluctuations and flicker in public low-voltage supply systems, for equipment with rated current  $\leq 16$  A per phase and not subject to conditional connection.
  - c. BS EN 62262, Degrees of protection provided by enclosures for electrical equipment against external mechanical impacts. (IK Code) And, shall meet a rating of at least IK08 for the whole lantern. (including the housing, gear canopy and glass cover)
  - d. BS EN 60529, Degrees of protection provided by enclosures. (IP Code) And shall meet a rating of at least IP66 for the whole lantern. (including the housing, gear canopy and glass cover)
7. All testing and certification, including lifetime projections shall have been undertaken with the lanterns mounted within a controlled environment at an ambient operating temperature of +25oC with the LED chipset installed within the lanterns.
8. Any testing undertaken or data acquired at lower temperatures, or based upon LED manufacturer's lifetime projections calculated at a nominal LED junction

temperature (Tj) must not be used to demonstrate compliance with any of the minimum requirements herein.

9. The luminaires shall be suitable for operation within ambient temperatures between -15°C and +35°C.
10. The luminaires are required for operation on an ESB Networks supply, which is declared at 230 volts  $\pm 10\%$  at 50 Hertz.
11. Power factor shall be  $\geq 0.9$  for both full loads and dimmed situations.
12. The luminaires shall be fitted with surge protection in accordance with EN 61643-11:2012 & A11: 2018 to a level of 6 kV differential mode and 8 kV common mode. The surge protection shall be the first component encountered in the circuit to ensure protection for all components within the luminaire.
13. The luminaire shall be of the Constant Light Output (CLO) type.
14. The rated input power and the total circuit wattage, in Watts, of the complete luminaire (including LEDs and LED Driver), shall be stated.
15. The Designer shall assess, from the design process, the correct luminaire and ensure that the new LED luminaire is supplied and pre-wired with minimum 2.5mm<sup>2</sup> artic flex cable for industrial use to BS6004 (formerly BS7919). The cable shall be sufficient be of an insulation category suitable for the luminaire and exterior applications appropriate to project area. The cable length shall be suitable for the distance between the designed luminaire position and the appropriate electrical supply point (*Cork County Council* owned cut- out). The number of cable cores shall be suitable for the power, LED driver re- programming and control requirements of the unit/circuit.
16. The luminaires shall be classified into a Risk Group in accordance with EN 62471:2008 – Photobiological Safety of Lamps and Lamp Systems. This risk group classification is to be advised by the supplier.
17. The luminaires shall bear the CE marking, awarded by an EU based certifying body.
18. Luminaires shall be manufactured in accordance with the European Directive on Waste Electrical and Electronic Equipment.
19. The optical unit within the luminaire shall be rated at least IP66.
20. The luminaire shall have an impact resistance rating to IK08 minimum on the complete luminaire, including on the luminaire body and on the LED module protectors.
21. The lanterns shall be available with internal or external shield options. The external shield must be suitable to fit to any of the 4 sides of the lantern.

22. The lantern housing shall be constructed from high pressure die cast corrosion resistant marine grade aluminium alloy in accordance with: EN AC 44100 or EN AC 44200 or EN AC 44300 and be powder coated conforming to appropriate European standards – final colour (grey, black if requested eg. Heritage lanterns). The alloy shall have less than 0. % of copper content in order to avoid corrosion.21
23. All coloured components of the luminaire shall be of the same colour code (RAL) and have the same visual appearance when viewed together.
24. Lanterns shall be finished in a high quality, ultra-durable and textured powder coating in a neutral RAL colour.
25. The coatings shall meet the requirements of: Qualicoat Class 1 Coatings BS EN 12206, Paints and varnishes. Coating of aluminium and aluminium alloys for architectural purposes. Coatings prepared from coating powder.
26. Access to the gear compartment shall be via a hinged canopy that shall be secured when in the closed position via a robust closing catch that facilitates tool-less operation.
27. The closing catch, hinges, exposed screws, grub screws, captive screws and other fixings shall be manufactured from a corrosion resistant material and protected in a manner commensurate with the lantern housing.
28. The lantern shall incorporate a robust bracing arrangement that shall securely support the canopy when open.
29. The lantern shall include a flat toughened glass cover to protect the LED module. Lanterns with exposed LED modules, or covers which are not manufactured from glass (including PMMA or polycarbonate) will not be accepted.
30. All lanterns must be maintainable on site with interchangeable parts i.e. the lantern does not have to be sent back to the factory for maintenance.
31. The lantern shall facilitate mounting via an integral spigot manufactured from corrosion resistant marine grade aluminium alloy and protected in a manner commensurate with the lantern housing. Fixing to the column or vertical or horizontal bracket shall be via a minimum of two separate stainless steel fixings or via threaded connection for top mounted Heritage lanterns.
32. The lantern shall be available with mounting spigots that accommodate both of the following requirements as a minimum:
 

Side-entry mounting	32mm to 60mm
Post-top mounting	60mm to 76mm

 The spigots shall be universal/interchangeable to allow vertical or horizontal brackets.

33. When, mounted, the Lantern shall be capable of facilitating each of the following tilt settings on- site:

- 10° to +10° for side-entry mounting in steps of 5° minimum and;
- 5° to +10° for post-top installations in steps of 5° minimum.

34. The lantern shall include a mechanism to achieve the various tilt angles that shall be secured in the final position using two separate fixings accessible without opening the lantern. Lanterns that rely upon the insertion of additional elements (such as metal washers or spacers), or that require the opening of a cover in order to set/fix the tilt angle are not acceptable.

35. The tilt angle settings shall be clearly and indelibly marked on the spigot or lantern, and shall be clearly visible without opening the lantern to ensure the correct angle can be set and checked easily.

36. The maximum weight of the complete luminaire shall be 15kg.

37. The lanterns shall have a maximum windage as per the following requirements:

38.

Column Height	Maximum Windage (m <sup>2</sup> )
<= 6m	0.15
<= 8m	0.17
<=10m	0.22

39. Cable entry shall be via a single M20 cable gland with strain relief, for cable diameters between 10-14 mm.

40. The control gear components shall be integral to the lantern housing and mounted within a gear compartment separated from the LED module.

41. The lantern shall provide a connection facility for the main incoming supply cable. (marked L,N,E)

42. The lantern must be available with optics that can meet a glare classification of at least G4 if necessary, complete with a range of optics.

43. The light output ratio of the luminaire shall be greater than 90% with an Upward Light Output Ratio on vertical and horizontal planes of no more than 0.5%.

44. All wiring shall be heat resistant and comply with I.S. EN 60598 or equivalent.

45. Active cooling systems utilising fans are not permitted. Passive cooling technology

shall be used to transfer heat from the luminaire to the air. Heat sink components or assemblies manufactured to take heat away from LEDs (that generate heat) shall be used. The Thermal management may comprise channels, fins or other geometries to increase the dissipation of heat.

46. The S/P ratios for the proposed luminaire and optic settings shall be provided and shall be at least 1.5 for neutral white and 1.2 for warm colour temperatures.
47. All LED luminaire complete with a new photocell as below:  
 All roads will be 35/18 lux On/Off;  
 Lanterns in the vicinity of pedestrian crossings will be 70/35 lux On/Off.
48. New LED lighting luminaires shall be a high-efficiency type selected from the SEAI Triple E Products register.
49. The Luminaire shall be fitted with a compatible 7-pin NEMA socket and pre-wired for use.
50. The LED Lantern for Pedestrian Crossings shall be provided with the specific pedestrian crossing optic “DPL1” (Left) or “DPR1” (Right).
51. For ease of future maintenance the CCC Street lighting Section seeks to ensure that the fewest lantern variants are used as possible.
52. Lantern’s glare rating shall be in accordance with Table 2 of DN-03038 below but in general should be G4 or higher

<b>Zone</b>	<b>Surrounding</b>	<b>Lighting Environment</b>	<b>Examples</b>	<b>Intensity Classes</b>
E0	Protected	Dark	UNESCO Starlight Reserves, Dark Sky	G6
E1	Natural	Intrinsically dark	National Parks, Areas of Natural Beauty etc	G5 or higher
E2	Rural	Low district brightness	Village or relatively dark suburban roads	G4 or higher
E3	Suburban	Medium district brightness	Small town centres or suburban locations	G3 or higher
E4	Urban	High district brightness	Town/city centres, high levels of night activity	G2 or higher

53. All components shall be in compliance with WEE Directive for recycling.



## LED Modules

1. The lanterns shall deliver an efficacy in excess of 130 CLO lm/W for warm white or 140 CLO lm/W for neutral white, at all lumen outputs and drive currents up to and including 700mA. The minimum lighting luminous efficacy of the complete luminaire at the proposed driver current shall be provided (in Lumens/Watt).  
Note: the luminous efficacy of the LED chip only will not be accepted. It must be given for the complete luminaire.
2. Lanterns shall not be driven at their maximum drive currents to allow the facility to increase ( in the region of 25%) the output on site, post installation, should a justifiable low level lighting complain arise. For example, within the Philips Luma type lantern, Cork County Council only allow the use of Luma micro between 0-5,000 lumens range, Luma mini, within the 5,000-10,000 range and Luma 1 between the 10,000-20,000 lumen range.
3. The colour rendering index (CRI) shall be a minimum of Ra 70
4. The initial Colour Temperature tolerance shall be no more than 5-step MacAdam Ellipse
5. The LEDs shall have a Correlated Colour Temperature (CCT) category of Warm White between the ranges of 2,700 – 3,300. Significant conflict zones ,such as roundabouts and in the vicinity of zebra crossings and Large Town Main Streets shall be neutral white 4,000k.
6. All LED life extrapolations must be based upon the Illuminating Engineering Society (IES) standard LM-80 provided by the LED source manufacturer. The LED source manufacturer must use a valid method for projecting LM 80, or equivalent, with test results to LM-80 based on recommended operating conditions.
7. Long term life projections must be developed in accordance with the Illuminating Engineering Society (IES) recommendations contained in TM-21 or equivalent using data obtained in accordance with LM-80.
8. The initial lumen output of the luminaire at the proposed driver current shall be provided (in Lumens).
9. The maintained lumen output of the luminaire at 6,000 hours at the proposed driver current shall be provided (in Lumens).
10. All testing and certification, including lifetime projections shall have been undertaken with the lanterns mounted within a controlled environment at an ambient operating temperature of +25oC with the LED chipset installed within the lanterns.
11. Any testing undertaken or data acquired at lower temperatures, or based upon

LED manufacturer's lifetime projections calculated at a nominal LED junction temperature ( $T_j$ ) must not be used to demonstrate compliance with any of the minimum requirements herein.

12. The minimum performance requirements of the lantern shall be L90B10 at 100,000hrs across the full range of outputs including the maximum drive current of 700mA and a lumen output of 35klm when subjected to a lantern outside ambient temperature of 25°C.
13. All energy consumption values provided must be based upon system power (i.e. the power consumed by the lantern when measured operating as a complete unit) at the average CLO level configured for a 100,000 hour period.
14. The LEDs shall be arranged on a suitable PCB such that they align behind dedicated lens-style optics which shall be designed to each provide the required light distribution footprint of the lantern; known as the overlay principal.
15. The LED modules shall be replaceable during maintenance events or for lantern upgrades.
16. Levels of uniformity should not be significantly adversely affected in the event of individual LED failures.

## LED Drivers

1. The LED driver shall be integral to the luminaire body and be securely fixed inside the luminaire gear compartment. Once disconnected, the driver shall be removable without the use of tools.
2. The LED drivers shall comply with the essential requirements of the following standards:
  - a. BS EN 61000-3-2, Electromagnetic compatibility (EMC). Limits. Limits for harmonic current emissions. (equipment input current  $\leq 16$  A per phase)
  - b. BS EN 61000-3-3, Electromagnetic compatibility (EMC). Limits. Limitation of voltage changes, voltage fluctuations and flicker in public low-voltage supply systems, for equipment with rated current  $\leq 16$  A per phase and not subject to conditional connection.
  - c. BS EN 61347-1, Lamp control gear. General and safety requirements.
  - d. BS EN 61347-2-13, Lamp control gear. Particular requirements for d.c. or a.c. supplied electronic control gear for LED modules.
  - e. BS EN 61000-4-5, Electromagnetic compatibility (EMC). Testing and measurement techniques. Surge immunity test.
3. The drivers shall include Surge Immunity and be capable of withstanding multiple surges of up to 8kV in differential mode, up to 6kV in common mode and up to 10kV single pulse.
4. The LED driver shall be programmed for constant light output (CLO). The CLO value shall be 90% of the initial lumen output.
5. The LED drivers shall have a minimum operational lifetime of 100,000 hours with a minimum of 90% survival during this period (L90B10).
6. The driver shall be factory programmed to a set dimming regime if required.
7. The LED Driver shall be re-programmable and allow for dimming of the luminaire
8. The driver shall be pre-programmed and capable of being re-programmable via pre-wired 5-core cables or wireless technology (such as Bluetooth) or another solution subject to acceptance of Cork County Council and adaptable to be integrated with the CMS at a later date to allow for the system to alter its control functions.
9. The LED Driver shall also have Dual Direction Communication in DALI protocols to allow for future remote monitoring of the installation.
10. The LED driver shall be capable of being programmed for linear multi-stage dimming using variable drive currents.
11. A maximum drive current of 1000mA shall be adhered to for all luminaires. All designs should be based on the luminaire operating at 75% of the maximum driver

current to allow for flexibility and future increases.

12. The LED drivers shall have terminals which are shrouded and indelibly marked to indicate all wiring connections and operating voltages.
13. The LED drivers shall be fitted with an automatic re-setting thermal cut out.
14. The LED drivers should achieve a power factor of  $\geq 0.9$  when operated at full load and in dimmed situations.
15. The LED modules shall be replaceable during maintenance events or for luminaire upgrades.
16. All drivers shall be CE certified and marked accordingly.
17. The LED Driver shall be enabled for use with a Central Management System (CMS).
18. The rated life of the proposed LED Driver shall be provided but shall be at least 10 years and shall be guaranteed to a minimum of 10 years.

## **Photometric Data and S/P Ratios**

1. The absolute photometric data indicating the optic setting and proposed driver current of the proposed luminaire must be provided. The data shall be supplied in electronic format (.ies/.cib/.ldt/.eul or equivalent). Note all files must be clearly labelled.
2. The S/P ratios for the proposed luminaire and optic settings shall be provided and shall be at least 1.2 for 2,700 – 3,300K and 1.5 for 4,000K.

## Testing and Certification

1. Testing of the luminaires, LED modules and LED Drivers shall be carried out by an independently accredited test laboratory, preferably located within the European Union as a complete unit and not in component parts.
2. The Certificate of Compliance of CE testing and marking of the complete luminaire (including LED modules and LED Driver) shall be provided from an EU based certifying body. A Declaration of Performance in addition to CE Marking is required.
3. Suppliers shall have available to them full details and certificates of all testing carried out and these must be provided on request. Details and certificates of testing shall include but is not limited to:
  - IES LM-79-08 test report for the luminaire.
  - IES TM-21-11 report for the luminaire with LM-80 chip data and in situ temperature measurement test data and shall clearly indicate the lumen maintenance after the test time expressed as a percentage of the initial lumen output, and the calculated and reported L80 and L90 values (in hours).
  - IES LM-80-08 test report for the LED chip to validate the data entered into the TM-21 report.
  - All Thermal Tests carried out on the luminaire and LED modules, including LED junction temperature testing and In-Situ Temperature Measurement Test (ISTMT) Report to validate ISTMT data entered into the TM-21 report.
4. The luminaires shall be tested and approved by an independent 3rd Party ENEC (European Norms Electrical Certification) national Certification Body and awarded the ENEC mark in accordance with CENELEC Operational Document CIG 021 & evidence of same to be provided.

## Documentation Required

The lantern provider may be asked to provide the following information:

- Full technical details and product data sheets for the proposed luminaire, LED modules, LED Driver, and photocell.
- Details of the thermal management of the proposed luminaire.
- Details confirming the warranties on the complete luminaire (refer to section LED Warranties) and how those warranties will transfer to the Cork County Council upon Completion.
- LED Luminaire Technical Details data sheet (Form 1 in Appendix B of the specification) with the details listed.

- Certificate of Compliance of CE Testing and Marking
- Full details and certificates of all testing carried out on the proposed luminaire and LED modules at an ambient temperature of 25°C shall be provided.

## LED Warranties

1. Luminaires shall be protected with a 10 year minimum manufacturer's warranty, as standard from the date of installation that shall provide replacement parts or whole lanterns (as appropriate) in the event of failure. Luminaires shall have a design life of 25 years (to correlate with 100.000 hours)
2. Luminaire warranty shall cover all luminaire components, inclusive of electronics, drivers, photocells, CMS nodes, finishes, IP Rating, LED Module failures etc
3. Further, the above will be unconditionally transferred to Cork County Council after the initial 12 month Contractor warranty period or when lights are taken in charge, in the case of privately developed housing estates.
4. The warranty shall include labour costs for at least the first 12 months post installation.
5. The warranty and any necessary after sales support for the LED lanterns shall be provided and supported directly by the lantern manufacturer and not be novated to the contractor or Cork County Council based upon a back-to-back arrangement with the driver manufacturer.
6. The manufacturer shall have a national after sales support network and be able to demonstrate the necessary assurances that they are in a position to support the warranty throughout the full defects period and beyond.
7. Cork County Council will not accept extended warranties which have future cost implications.

## Photocell Specification

A seven prong twist lock NEMA socket, or a seven prong twist lock NEMA socket with an electronic photocell shall be fitted to the top of the luminaire. Where standard photocells are not feasible for heritage luminaires, miniature versions shall be installed subject to the approval of Cork County Council.

Photocells shall be SELC or Zodian or an approved equivalent.

The socket/photocell shall be sealed with a weatherproof gasket and secured to the

luminaire body by non corrosive fixing screws. The photocell shall have a minimum guarantee of 6 years and must comply with the latest version of BS 5972.

The photocell control shall switch on/off the luminaire as outlined below:

- Lanterns on all roads use 35/18 lux On/Off;
- Lanterns in the vicinity of pedestrian crossings will be 70/35 lux On/Off.

They shall be designed where possible so that in the event of a fault occurring in the unit they cause the load to be switched “on” so that the fault can be detected.

PECs shall:

- a) be secured to the lantern canopy;
- b) include a delay device to prevent the lamp being switched in response to transient changes in light conditions;
- c) be indelibly marked with:
- d) the manufacturer’s identification mark; and
- e) the model number; and
- f) the switch on level;
- g) be provided with a gasket or grommet to maintain the required degree of protection;
- h) be installed to the manufacturer’s instructions

***A useful Lantern checklist for compliance against Specification is contained in Appendix I***

## **8.0 Exterior Lighting Columns and Brackets**

### **8.1 General Principals**

- Design calculations for columns and brackets are subject to review by Cork County Council and shall be submitted with proposed exterior lighting scheme designs if requested;
- Public lights should not be erected beneath or adjacent to HV & LV overhead powerlines without explicit approvals from ESB Networks. Ref. ESB Code of Practice for Avoiding Hazards from Overhead Electricity Lines.
- Hanging baskets are not permissible on any columns to be taken in charge by Cork County Council.
- The designer shall specify the use of passively safe columns where setback of 7m for conventional columns cannot be achieved on routes with design speed of 85 km/h and over as appropriate per the requirements of BS EN 12767: 2007 & TII DN-LHT-03038 August 2018 & ILP Technical Report 30 Passive Safety. Guidance on the Implementation of Passively Safe Lighting Columns and Signposts. The specification of the columns and any brackets (including the foundation types) is specific to the location and local circumstances.
- On traffic routes **passively safe columns** may be required within Urban Zones subject to a Risk Assessment as outlined in BS EN 12767. TR30: GUIDANCE ON THE IMPLEMENTATION OF PASSIVELY SAFE LIGHTING COLUMNS AND SIGNPOSTS is a useful reference document.  
TII's 'Design of Road Lighting for the National Road Network', DNLHT-03038 -August 2018, gives guidance that lighting columns located within the Clear Zone in areas subject to a speed limit greater than 85km/hr or at Urban gateways, shall require the use of passively safe columns. ***Cork County Council's policy on passive columns on non-national routes is aligned to TII policy, as outlined above.***
- The TII specification requires that the electrical supply to passively safe columns shall automatically electrically disconnect within 0.4 seconds to ensure that any vehicles that strike the columns do not become live on impact. This is achieved by the use of impact sensors located within the columns, which connect to an SIS unit located in a pillar or underground unit, where tripping of the circuit occurs if a column is struck by a vehicle.



## 8.2 Lighting Columns

Lighting columns shall be designed and certified to I.S. EN40 Series. Lighting columns need to be protected from the effects of the weather, pollution and other environmental elements. Steel lighting columns will quickly deteriorate if they are not provided with, as a minimum, a protective system such as hot dipped galvanizing. Further protection or visual enhancement may also be given by the application of an additional protective system such as paint or powder coating. In the case of rooted columns the section which is immersed in the ground must be treated with a bituminous preservative, to at least 150mm above ground level.

Lighting columns manufactured from aluminium, stainless steel or composite materials generally require no additional protective coatings to be applied. To maximise the life of the lighting column, any protective systems need to be maintained throughout its life.

## 8.3 Column heights

***Generally, lighting columns within housing estates should be 6m high.***

***Generally, lighting columns on Local and Regional Roads should be 8m/10m high (10m on very wide R-Roads).***

***Generally, lighting columns on National Roads should be 10m high.***

***Generally, lighting columns on Motorways/dual carriageways should be 12m high.***

***Generally, for cycleways & greenways 4m-6m mounting heights are acceptable.***

## 8.4 Protective coatings and their application to Columns

Site-applied protective coatings vary from the simple oil-based paint system up to high-build multiple coat systems. Many of the high-build protective coatings provide superior protection and life to the simple oil-based paints, but do not have the same overall high quality of finish. New high-build multi-coat systems which have a higher quality of finish are now available and should be utilised.

The frequency for the reapplication of protective systems to lighting columns should be determined taking account of the following matters:

- Condition and age of equipment.
- Level of atmospheric pollution.
- Location of equipment.
- Type of protective system used.
- Other environmental factors

Further guidance on the application and maintenance of protective coatings can be found in the Institution of Lighting Professionals " *Technical Report No. 26 A Practical Guide to the Painting of Steel Lighting Columns and Bracket Arms.*

Columns located in a marine environment where they will be likely to experience wind

borne water spray should be treated with an extra coating as outlined in Appendix D, Figure 12.

## 8.5 Design Standards for Columns

Lighting columns selected for use on new schemes shall, in general, be tapered hexagonal / octagonal / hexadecagonal (16-sided) galvanised type and all columns shall be galvanized on both the inside and outside to BS EN ISO 1461: 2009.

Columns shall have a double locking access door positioned facing oncoming traffic. Ref Appendix D, Fig 11. Deviations from these types of columns will required the prior approval of the public lighting engineer.

Passive columns will be required under certain circumstances as outlined in 8.1 above.

Exterior lighting columns shall be designed to the BS-EN 40 latest revision, family of standards, viz.:

(a)	IS EN 40-1:1992	Lighting Columns. Definitions and terms.
(b)	IS EN 40-2:2004	Lighting Columns. General requirements and dimensions.
(c)	IS EN 40-3-1:2013	Lighting Columns. Design and verification. Specification for characteristic loads.
(d)	IS EN 40-3-3:2013	Lighting Columns. Design and verification. Verification by calculation.
(e)	IS EN 40-3-2:2013	Lighting Columns. Design and verification. Verification by testing.
(f)	IS EN 40-5:2002	Lighting Columns. Requirements for steel lighting columns.
(g)	BS PD 6547:2004	Guidance on the use of BS EN 40-3-1 and BS EN 40-3-3
(h)	IS EN 1991-1-4:2005	Eurocode 1: Part 1.4. Basis of design and actions on structures. Actions on structures. Wind actions.
(i)	BD 94/07	DMRB Vol.2 Highway Structures Design (Substructures and Special Structures), Materials. Section 2 Special Structures Part 1 BD 94/07 Design of Minor Structures (Formerly BD 26/99 & 26/04)
(j)	NRA BD 26/04	NRA Addendum to BD 26/04
		BS EN 12767: 2007 & NRA & ILP Technical Report 30

\* **Note:** Where contradictions or ambiguities arise between the standards, the standard listed higher in the order of precedence shall govern.

Decorative columns may be acceptable in other shapes/materials as long as they comply with EN40 and receive prior approval by the Council's Public Lighting Engineer.

Columns proposed to be installed in town centre locations or at locations as directed by Cork County Council may be required to be finished with a proprietary paint to an agreed BS or RAL colour which takes account of the surrounding environment.

The lighting column manufacturer shall be registered with and certified by either NSAI, British Standards Institute of Quality Assurance Services or Lloyds Register Quality Assurance Register for the design, manufacture, supply and verification of road lighting columns and brackets under their quality assessment schedule to ISO 9001.

The quality assurance certification shall relate to the specific lighting column material being proposed. Cork County Council reserves the right to request proof of certification from the proposed column manufacturer.

- ***Plain tubular stepped columns, are not desirable due to issues with deterioration of the welded joint.***
- An earthing connection shall be provided in the column base compartment. The fastening screw for this connection shall be stainless steel with an M8 coarse thread.
- The structural loading on the columns and brackets shall be calculated by the proposed column manufacturer / supplier in accordance with IS EN 40-3<sup>5</sup>-1, using the Rationalised Wind Factor calculation as described in BS PD 6547.

The Rationalised Wind Factor (RWF) shall be: 587N/m<sup>2</sup> and the exposure category shall be Category II.

(Note: Calculations using the 60 minute storm or the 3 second gust wind speed will not be acceptable.)

- The structural design of the columns and brackets shall be verified by calculation by the proposed column manufacturer / supplier in accordance with IS EN 40-3<sup>5</sup>-3. The partial safety factors used in the calculations shall be:

Partial safety factor for materials	1.15
Partial safety factor for dead loads	1.20
Partial safety factor for live loads	1.40
- All columns in urban areas must be designed to include the possible future mounting of a stationary sign 450 mm. sq. mounted at a height of 2m.
- Any non-lighting equipment (including signs etc.) may only be installed on exterior lighting columns or poles with the explicit permission of Cork County Council Roads (Public Lighting) Division or ESB Networks where applicable.
- Columns shall have a design life of a minimum of 25 years in accordance with IS EN 40-3<sup>5</sup>-3; and shall be certified.
- When rooted columns are proposed, the column planting depth is to be treated with a bituminous preservative on the outside surfaces. The bitumen shall extend to at least 150mm above ground level.

- The bottom of the access door to the column should be of the order of 1.2m-1.3m above ground and the door should be on the side facing oncoming traffic. The door shall be lockable and accessed by a standard key. A standard detail for a hexagonal column is outlined in Appendix D, Figure 2.
- A marine plywood baseboard is to be fitted in each column. Three coats of intumescent varnish shall be applied to the baseboard in order to prevent fire propagation. The rate of coverage shall be 2.5 square metres per litre in order to provide class 0 protection. The clearance between baseboard and inside face of door when secured to be not less than 100mm;

## 8.5 Maintenance of Columns

Developers shall take into consideration the location at which an exterior lighting column is to be installed with a view to the following:

- The level of vandalism likely. More robust columns are required in areas of high instances of vandalism.
- Columns that are to be installed in locations inaccessible to a maintenance truck, e.g. on steps / embankments / narrow laneways etc. must be of a hinged design to allow for maintenance. The minimum paved width required for a truck/van fitted with a hoist is 3.0m. If this is not possible, then hinged columns shall be installed as the alternative.
- Columns erected in coastal area likely to be affected by sea water, breezes shall be painted as well as galvanised. Ref. Appendix D, Figure 12.
- Exterior Lighting columns, micro/midi pillars and ducts, likely to be taken in charge by Cork County Council, shall not be erected on ground likely to remain private / inaccessible, e.g. private gardens, ESB / Bord Gais Substations, enclosures etc.;

## 8.6 Outreach Brackets

- Outreach brackets may be used. ***In general Cork County Council favour either post-top, a vertical extension or a max outreach of no more than 1m.***
- New/replacement over the conductor brackets on ESB Network poles shall have a maximum outreach of 0.5m, as specified currently by ESN.
- Non-standard Outreach Bracket are to be designed and certified prior to use, particularly where decorative brackets are being used; Evidence that such brackets meet the standard shall be forwarded to the Public Lighting Engineer for approval before they are incorporated into the works.
- The column and bracket assemblies shall conform with the deflection requirements of Class 2 as defined in IS EN 40-3<sup>5</sup>-3;

## 8.7 High Masts

This is the term used to describe masts used to mount floodlights at heights ranging from 10m to 60m which are designed for 25 year life spans.

Typical applications are docks, harbours, railyards, airport aprons ,sports arenas, and motorway interchanges where large areas are required to be lit.

High masts can be of the base hinged type or have an electric motor with winch installed to facilitate lowering of floodlights to ground level for maintenance. Rigid platform types are also used with access for maintenance by mobile elevated work platform (MEWP).

Latterly TII have discouraged the use of high masts at interchanges due to the high maintenance costs involved in their certification & maintenance.

ILP Guide 07 “High Masts for Lighting & CCTV 2013 “ provides full details on the specification and design of High Mast Installations .

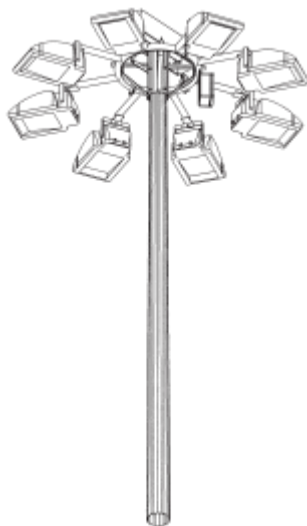

High Masts with lowering type lantern carriage & Rigid Platform are subject to inspection, testing & operation of winches in accordance with requirements of SHAWW (General Application) Regulations 2007, S.I. 299 of 2007.

EN40 standard applies up to 20m high masts. ILP Technical Guidance Document 07 applies thereafter.

***Cork County Council does not favour the use of high mast lighting as an alternative to conventional column lighting except in exceptional circumstances and with the prior approval of the Public Lighting Engineer.***

## **9.0 Compatibility of Components**

There is a significant issue of compatibility in choosing appropriate replacement components or assemblies. Generic substitutes may not have the same visual appearance or give the same lighting performance as the original equipment. The main issues to be considered are:

### **9.1 Lighting Performance**

The original design for lighting any given road, footpath or area usually depends on optimising a number of factors, environmental, optical and functional (relating to anticipated use). From this process the optimum choice of luminaire and their spacing and mounting heights will be determined to achieve a specific performance in accordance with the requirements of BS 5489–1: 2013 and BS EN 13201.

It is important that maintenance repairs do not introduce components (particularly luminaires) or carry out adjustments (reflector positions, lamp positions) that affect the designed optical performance. Changes in luminaire type will require assessment, prior to installation, to establish that the distribution and light control are at least equivalent to that of the original installed, e.g. full cut-off (flat glass) luminaires, which have been installed to reduce the night time visual impact of the lighting and sky-glow, should not be replaced with semi-cut-off bowled luminaires during maintenance activities.

LED luminaires may be specifically designed to varying pole intervals and any replacements should be of compatible design.

### **9.2 Maintenance**

Many high-speed roads are often subject to restrictions on the times that access can be made available for maintenance activities and therefore every effort must be made to ensure that lights not working are repaired and put back into full operation in the shortest time on-site. This often leads to luminaires being replaced rather than repaired on-site. However, this is not an excuse to use the wrong type, make or model of luminaire.

Maintenance activities on restricted access roads have to be planned in advance and this should allow the purchase of the correct luminaires to replace those that need replacement.

Care should be taken when ordering replacement luminaires to ensure that the correct body type, reflector type and lens type are specified to match those in situ on the road. In this way the aesthetics and the performance of the lighting system will be maintained. Good records and knowledge of the lighting system will provide good guidance as to the quantity of units needed for maintenance purposes.

**9.3 Mechanical performance** will also be affected by changes in mounting height, bracket out-reach, spigot angle and through the incorrect alignment of bracket and luminaire relative to the lit area.

**9.4 Lighting column replacement** has to be considered on an individual basis as movement to a different location and may affect light distribution potentially reduce performance.

**9.5 Electrical performance.**

Replacement control gear must be capable of operating the lamp no less efficiently than the original control gear. New or revised circuit wattages must be recorded in the inventory.

**9.6 UMR – Unmetered Registry**

All changes to lanterns which affect their burn wattages or timings, on unmetered supplies, must be notified to the UMR so that the appropriate energy savings/costs are accrued.

**9.6 Operating hours**

Photocells have standardised switching levels relating to a total number of operating hours per annum. The cells also have specific characteristics relating to power consumption, reliability and stability that effect the operating hours and the charging regime. Changes in photocell types and/or operating hours must be recorded in the inventory. The replacement of older photocells can bring improved accuracy in switching, reducing operating hours and energy consumption.

***Cork County Council policy is to use 35/18 photocells generally with LED lighting but 70/30 on zebra crossings and for consideration in Town Centre Main Streets.***

***Cork County Council policy is to use dusk/midnight photocells for amenity walks, decorative lighting of historic buildings and other locations likely to be used only during early hours of nighttime e.g. sports facilities and rural schools.***

***Cork County Council does not favour the lighting of playgrounds for use after dark but requests for lighting to counteract anti-social behaviour will be considered.***

## **10. Cable Design and Electrical Service Design**

**10.1** The electrical services design for a scheme shall be undertaken to comply with the relevant sections of ETCI National Rules, viz IS:10101 and ET: 211. In particular the requirements set out in section 714 of IS:10101 shall be complied with.

The detailed cable design shall be undertaken to match the calculated electrical load which would typically allow between 4 and 8 fittings to be supplied per phase. The provision of earth loop / fault level calculations and circuit disconnection (fuse rupture times) shall also be completed at the design stage.

Exterior lighting schemes, with cable lengths in excess of 300 meters require careful design to meet the earth loop impedance requirements of IS: 10101. Cable runs in excess of 300m from a connection point ( MP) would need to be designed and signed off by a competent Electrical engineer and may require the installation of a direct feed interim micro/midi-pillar or in some cases of extreme length, the need for a 3 phase supply may be an option to be considered. Early engagement with ESNB representatives in regard to supply points and acceptable cable runs is advisable on projects where the determination of suitable connection points is complex. ***Housing estate developments should limit cable runs to a maximum of 300m or approx. 9 lights so as to maintain an unmetered supply <2KV within acceptable voltage loss limits.***

Disconnection / fuse fault disconnection times ( 0.5 secs) shall be in compliance with those set out in IS: 10101 (National Rules for Electrical Installations) rather than those specified in BS 7671 for Public Lighting and Street Furniture.

**Note:** In some cases it may be prudent to refer the electrical services designer to other Irish, UK or European Electrical Design Standards, e.g. ILP Guidance Notes.

**10.2** In all cases power supply cable from the following categories shall be installed:

- SWA Cable to BS 6346 (0.6 / 1kV);
- SWA Cable to BS 5467 / I.S. 273 (0.6 / 1kV);
- NYCY cable to DIN VDE 0276 – 603 (0.6 / 1kV).

Normal mains cable size used in residential schemes is a minimum of Single Phase 6 sq.mm. as supply up to column fuse board and 2.5 sq.mm from fuse unit to lantern, (1.5mm<sup>2</sup> is acceptable only on columns <8m high).

Good practice restricts the number of lights per circuit to a maximum of 10 lights, either direction from the connection point, so as to ensure that excessive lengths of roadway are not left in darkness as a result of an electrical fault.

Protection of service pillar cable circuits shall be by BS 88 -3 Type C fused MCB's with 25 amp main fuse.

However, for all new lighting installations, where the cable to the lights is no more than 3 x 6 sq. in size, then Type B MCB's are acceptable.



For all existing lighting circuits, even if retrofitting to LED, retain the Type C MCB's.

***Underground cables shall always be contained in red coloured recognisable ESB ducting at appropriate depth as outlined in the latest version of the 'purple book', Guidelines for managing Openings in Public Roads –DoTTaS and always protected by a warning tape indicating buried electrical services.***

### **10.3 Micropillars/Midipillars**

New Public Lighting installations, using an underground supply, must always be connected through a micro/midi-pillar, serving public lighting installations only.

A midi-pillar, containing surge protection, on top of normal connections, MCB's/fuses etc., is increasingly being insisted upon by Safe Electric before they will approve a RECI cert and hence, going forward, ***the midi-pillar, (inclusive of Type 2 surge protection unit to an appropriate level) must be used on any new Public Lighting schemes.*** A detail on these, new midi-pillars is outlined in Appendix D.

***It is not acceptable to connect any other type of new installation (e.g. pedestrian crossing lights) through a PL micro/midi-pillar.***

***Public Lighting installed along the Public road at the curtilage of a development shall be connected via a separate micro/midi-pillar (and MPRN) to any lights within the development itself mainly to facilitate separate taking in charge of the public road utilities as against those within a development.***

***Micro/midi-pillars shall be separated from mini-pillars by a distance of at least 2m, except in very exceptional circumstances where they are cross bonded .***

**10.4** Where ESB high voltage cables (11 KV / 22 KV) cables run in parallel with Exterior Lighting cables in ducts a minimum separation of 300 mm shall be maintained. Where ESB high voltage cables and Exterior Lighting Cables cross they shall do so at right angles. The requirement of crossing at right angles also applies to gas mains;

**10.5** Fuses shall have a minimum rupture capacity of 16 kA;

**10.7** Generally, the main customer service pillar customer fuse rating shall not be greater than 25 Amps.

**10.8** ***The use of circuit breakers (MCB's) in exterior lighting columns is not permitted by Cork County Council.*** Fused isolators / disconnectors, such as Lucy MC040SLF fused isolators /or equivalent, shall be used in Exterior Lighting Columns.



Column Base Fuse Cut –Out

- 10.9** Exterior Lighting cables shall not be jointed in inaccessible locations particularly where water ingress is likely. Inspection chambers / draw pits shall be installed at both sides of under carriageway crossings of duct and at every > 90° direction change
- 10.10** The availability of electricity supplies shall be confirmed by the Distribution System Operator (DSO) ESB Networks, prior to design of the exterior lighting scheme; Proposed locations for micro/midi pillars, agreed with ESB Networks, shall be shown on drawings.
- 10.11** Where upgrades to exterior lights on overhead network poles is being undertaken electrical isolation boxes (IP 65) approved by ESB Networks shall be fitted on the supply connection to each luminaire. These isolator boxes shall meet the requirements set out in the National Code of Practice for Customer Interface 5<sup>TH</sup> Edition 2021 as published by ESB Networks.
- 10.12** All upgraded luminaries shall be controlled via an integral photocell and not make use of the switchwire as was the practice in the past.
- 10.13** Main road exterior lighting schemes shall have power supply infrastructure installed with a minimum of 25% spare capacity (Maximum Installed Capacity at Customer Service Pillar, Cables to be sized for 25% additional load and at least 25% additional length) to allow for future extension.
- 10.14** *Cork County Council does not accept exterior lighting schemes that are centrally controlled in the interest of energy conservation, scheme reliability and public safety. As mentioned previously, each luminaire shall have a photocell or sub-miniature photocell.*
- 10.15** The installation of schemes in Residential Areas shall comply with the Code of Practice for Public Lighting ET211: 2003 or latest upgrade. All exterior lighting schemes shall include the provision and installation of a Customer Service Pillar (Micro/midi Pillar).

## **11. Small Civil Works – Access Chambers & Ducts**

**11.1 Exterior Lighting ducting** shall generally be 50mm diameter red polythene with smooth interior to IS 135 Class B / BS5306 Class B. Ducts shall be buried to the correct depths as specified in the ETCI National Rules (ET: 101). Minimum cable bending radii shall be observed;

***Cork County Council's preference is for ducting to run directly from micro/midi-pillar to streetlight and on to the next streetlight etc. but there may be situations where this is not the best option and chambers may be required.***

**11.2 Large Inspection Chamber:** All access chamber covers on the footpath to cater for a change of direction shall be ductile iron with galvanized steel frame with frame opening 615mm x 615 mm to EN 124 B125 marked "Public Lighting" or "Traffic" with M16 stainless steel locking bolt. Lock shall make provision for replacement of bolt and nut if damaged. Cover & frame shall be certified by an accredited Third party;

**11.3 Medium Inspection Chamber:** Access chamber covers on the footpath for straight through services shall be ductile iron with galvanized steel frame with frame opening 720mm x 260 mm to EN 124 B125 marked "Public Lighting" or "Traffic" with M16 stainless steel locking bolt or similar approved. Lock shall make provision for replacement of bolt and nut if damaged. Tapping of frames is not permitted. Cover and frame shall be certified by an accredited Third party;

**11.4 Small Inspection Chamber:** Access chamber covers on the footpath for column connections shall be ductile iron with galvanized steel frame with frame opening 385mm x 260 mm to EN 124 B125 marked "Public Lighting" or "Traffic" with M16 stainless steel locking bolt or similar approved. Lock shall make provision for the replacement of bolt and nut if damaged. Tapping of frames is not permitted. Cover and frame shall be certified by an accredited Third party;

**11.5 All Inspection Chambers on carriageways** shall have the same dimensions as those listed small, medium and large above. In all cases the chamber cover shall be to EN 124 Group 4.

High strength engineering brick or in situ concrete should be used to make up the manhole walls directly under the frame. Standard concrete blocks or bricks will **not** be acceptable. The engineering bricks shall comply with BS EN 772 (formerly British Standard 3921: 1985). Mortar shall have 1:3 cement sand dry volume ratios. The sand shall comply with BS EN 13139, BS 1200: 1996;

Chamber covers and frames shall be manufactured with certification by a suitably licensed third party (NSAI, Lloyds Register or British Standards Institute of Quality Assurance Services).

## **12. Electrical Supply (Metered & Un-Metered)**

**12.1** The electrical supply shall incorporate an un-metered supply for schemes with an energy demand of less than 2kVA or a metered supply point in an approved galvanised steel cabinet for circuits with a demand greater than 2 KVA. ***Cork County Council prefers unmetered lights generally and any deviation from that policy requires justification and approval of the Public Lighting Engineer.***

The connection from the ESB mini-pillar/pole to the micro/midi-pillar/ meter cabinet shall be provided through a continuous length of red coloured polythene ducting (50mm/100mm diameter) at a depth of 600mm for connection to Single Phase Pillars, and 125mm. duct for connection to 3 Phase pillars. The details on Customer Service Pillar's may be found in The National Code of Practice at [www.esb.ie/esbnetworks](http://www.esb.ie/esbnetworks)

The Developer shall bear the cost of the new electrical power supply connection and shall pay for all outstanding energy bills up to the date the scheme is taken in charge. For the avoidance of doubt, new electricity supply connections are to be applied for in the name of the Developer and not Cork County Council Roads (Public Lighting) Division.

### **i. Un-Metered – Schemes less than 2 KVA**

- a) Red coloured duct (50/100mm diameter), with smooth interior wall, polythene ducting shall be installed to cater for supplies to a customer micro/midi-pillar from the ESB mini-pillar/pole.
- b) Red coloured 50mm duct, with smooth interior wall, polythene ducting shall be installed to cater for connections to each of the columns thereafter.

### **ii. Metered Supplies – Schemes greater than 2 KVA**

- a) Red coloured duct (50/100mm diameter), with smooth interior wall, polythene ducting shall be installed to cater for supplies to the metered supply cabinet;
- b) Red coloured 50mm duct, with smooth interior wall, polythene ducting shall be installed to cater for connections to each of the columns thereafter.

In the case of metered supplies, it is recommended that location of the meter cabinet be selected to cater for all further up-grades to lighting, traffic signals and signs etc. in the area with details to be agreed with ESB Networks.

The metering pillar shall be located in a public area, adjacent to a footpath & at a level which is not liable to be effected by flooding.

## 12.2 Earthing & Bonding

Earthing and bonding shall be in accordance with the requirements of section 714.54 of IS 10101.

## 12.3 Unmetered supplies certificate

Trading methods require Cork County Council to submit an accurate inventory to the UMR for lighting under its control. The format of the inventory data required for each light is outlined in Appendix B, Figure 1. There are 106 attributes to be recorded, some deemed mandatory (M), some mandatory future (MF) and some optional. The MF attributes are now mandatory also at this stage and of the optional fields, those marked by an \* are deemed required by Cork County Council.

On validation of the inventory, the DNO (ESB Networks) will issue an Unmetered Supplies Certificate (UMSC), which must be made available to the prospective Electricity Supplier. Currently, all unmetered loads can be considered for inclusion on the Unmetered Supplies Certificate provided the equipment has a predictable load and operating hours, and is less than 2,000 watts.

UMR will require metering for equipment with an installed load greater than 2000 w. This is particularly relevant for equipment fed via highway power supplies from a feeder pillar. These types of supply should be discussed with the DNO (ESB Networks) before the inventory is submitted and at the time application is being made for new supplies. ***Cork County Council require that all supplies in housing estates are unmetered by ensuring that sufficient micro/midi pillars are installed throughout the development to ensure that no particular supply will exceed 2,000 watts.***

## 12.4 Agreements

a) Connection Agreement. All customers are required to enter into a connection agreement with the Distribution Network Operator (ESB). This agreement sets out the terms and conditions under which a supply is taken from the ESB network. The major part of the connection agreement will deal with the validation of the load connected to the network. It is essential that the inventory fairly represent the customer's connected load, as it can be subjected to audit by the UMR.

Any inaccuracies in the inventory could result in a factor being applied to the inventory to compensate for them. Power factor correction is one source of possible inaccuracy in measuring the electricity consumed and the ESB have the right to apply a factor to compensate for low power factor if they can demonstrate that it is below the level specified in the agreement.

b) Supply Agreement. The customer must enter into a Supply Contract with their chosen supplier of electrical energy. This shall remain in the name of the Developer until the scheme is formally taken in charge.

### **13. Lighting Engineering Consultants**

Cork County Council aim to work with Developers and their lighting design specialists to help achieve a good quality design for street lighting in accordance with BS & EN codes of practice, national rules for electrical installation “ETCI regulations” and this document.

***Cork County Council requires that Public Lighting be designed by a competent Public Lighting Designer proficient in the use of Public Lighting Design Software. Lighting Reality is the preferred software.***

The illuminance / luminance at conflict areas should be as per BS5489 and EN13201 for the particular scheme/location.

***Cork County Council require that Traffic Route Scheme designs be further checked and signed off by an Electrical Engineer who is experienced and competent in public lighting design incorporating the use of Public Lighting Design software.*** The Designer/Electrical Engineer may be required to demonstrate that he/she has an adequate knowledge and understanding of all current public lighting standards.

***Public Lighting Designers need to liaise with the development’s Architects, Landscape designers and the proposed Public Lighting installation contractor to ensure that conflict between elements is avoided so that each component can operate effectively, to its design standard.***

***Lighting designs can be assessed against environmental impact by following the process outlined in the ILP<sup>1</sup> Guidance document illustrated here.***

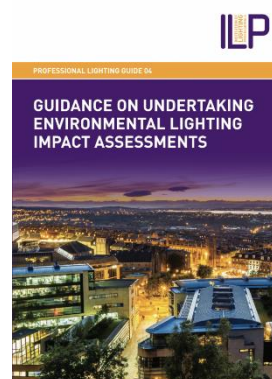

Typically, copies of the following Ordnance Survey Ireland Maps and drawings identifying the site location and elevation details would be required to undertake a Lighting design:

OS Map Scale 1:1000

OS Map scale 1:2500 where 1:1000 not available.

OS Site Detail Drawing Scale 1:500 or 1:250

Front Elevation of the Building & Side Elevations of the building if necessary.

On site measurements of typical lantern offset and in the case of retrofit, the existing mounting height and bracket details.

***Cork County Council’s Public Lighting Section, require to be provided with the Lighting Reality report for any scheme designs requiring the approval of Cork County Council along with a 1:500 scale map showing the design lux contours.***

## **14. Street Lighting – Equipment Manufacturers and Suppliers**

Lighting schemes in the charge of Cork County Council include equipment manufactured by various suppliers such as Phillips (Signify), Thorn, Urbis and others (subject to prior approval). In order to facilitate maintenance Cork County Council recommend the use of common brands, from well established Lighting manufacturers, for which spare parts are likely to be available for the whole life duration of the asset. There is also a need to limit the number of lighting brands being used so as to limit the range of spare parts required to be held by the Public lighting Maintenance Contractor.

Approval to the use of a proposed lantern brand, outside of the commonly used brands, should be sought from the Public Lighting Engineer at an early stage in the Design process, where exceptions may be warranted for the use of decorative lanterns or site specific brands to match existing.



## **15. Electrical Contractors**

Electrical Contractors, proposed for the erection of Public Lighting, shall be experienced in the supply and installation of exterior lighting schemes. They shall comply with ETCI National Rules and shall be responsible for coordinating the application to ESB Networks for the connection and to an energy supplier for the supply of electrical power.

The Developer shall bear the cost of the new connection fee and will pay the energy bill until the scheme is taken in charge by Cork County Council Roads (Public Lighting) Division.

Only Electrical Contractors registered with RECI/ Safe Electric or ECSSSA, are permitted to install Public Lighting likely to be taken in charge by Cork County Council and only those electricians who are trained by ESB Networks and authorised by Cork County Council are allowed to work on lights on ESB Network poles within the county. Those authorised are currently limited to the Public lighting Maintenance Contractor.

The ESB have revised their requirements document for Contractors working on lights on ESB network poles and the new document is entitled

### **ESB Requirements for Work on Public Lighting on ESB's Networks - 2020**

A second document entitled

### **Minimum Standards for Public Lighting Work Activities (PLWA)**

goes into greater detail and outlines PL Live Work Approval procedures for different tasks.

This is a table from the ESB Requirements for Work on Public Lighting on ESB's Network – 2020 which shows what type of work can be carried out on public lighting based on training and approvals.

<b>Type of Work</b>	<b>Non-Electrician</b>	<b>Electrician (but no PL Live Work Approval)</b>	<b>Person with PL Live Work Approval</b>
Opening / removal of door on a PL column fed by an underground cable from an ESN source which has already had its supply isolated	√	√	√
Opening / removal of door on a PL column fed by an underground cable	X	√ *	√



from an ESNB source which has not had its supply isolated			
Replacing bulb / cleaning bowl / covering photo-cell on a lantern on a directly fed PL column (i.e. PL column fed by cable)	√	√	√
Replacing bulb / cleaning bowl / covering photo-cell on a lantern mounted on ESNB pole and outside vicinity zone	X	X	√
Switching operations, operation of a test switch or testing for voltage in PL column within the vicinity zone	X	√	√
Live Work (see definition below)	X	X	√

A qualified electrician shall be permitted to open / remove a door on a PL column fed by an underground cable from an ESNB source which has not had its supply isolated, subject to the electrician having received the appropriate half day training course on how to safely perform this task. This training course can be provided on request from ESNB.

For clarity, a person with PL Live Work Approval shall be a qualified electrician.

All work in which the worker reaches into the Vicinity Zone (within 300mm of live ESNB apparatus) with either part of his / her body or with tools, equipment, or devices being handled. All work within the Vicinity Zone or on PL columns directly fed from an ESNB source shall be considered Live Work.

## 16. Lighting of Pedestrian Crossing & Traffic Island

### 16.1 Definitions

#### Pedestrian Crossing

A Pedestrian Crossing is a surface area provided across a carriageway as an amenity where pedestrians are encouraged to cross to give safe access and easier movement.

Uncontrolled, generally without Markings	With or without Central Refuge	
	Central Refuge with illuminated beacon	
Controlled, with Markings	ZEBRA	with or without refuge
	PELICAN	With or without staggered refuge
	TRAFFIC SIGNALS	with or without pedestrian aspects
	PUFFIN	With pedestrian monitoring phase
	TOUCAN	Shared pedestrian & cycle facilities

Generally such crossings will be in Urban areas where overhead public lighting exists. Existing street lighting is usually deemed sufficient for uncontrolled crossings or those pedestrian crossings which are the push button red/orange/green type. Zebra crossings however, do give a sense of priority to the pedestrian, which may not be as evident to the motorist on a dark wet night and hence ***Cork County Council policy is that zebra crossings should be lit to the higher standard specified under TR12 Lighting of Pedestrian Crossings.*** This standard can be achieved by installing additional lighting columns adjacent to the crossing or by the use of integrated zebra crossing column lights. Uncontrolled crossings on busy routes, such as National routes, may also warrant extra lighting.

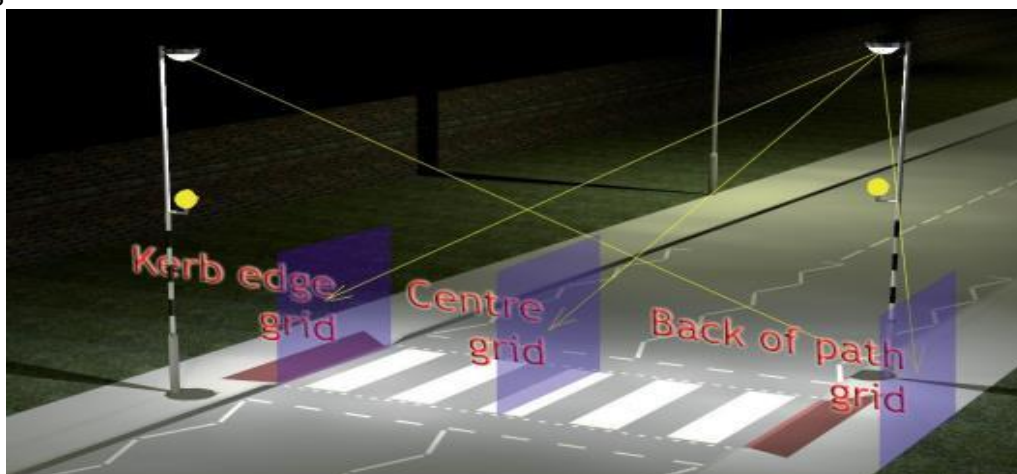

Layout details as shown in Annex D Figs.( 16-21 ) of TR12.

**16.2 Supplementary night time lighting** should be provided at all new zebra crossings, unless the requirement can be achieved through upgrading of existing adjacent lights, to TR 12 standard, possibly by the addition of an extra lower level light on existing lighting columns. The aims are to;-

- Make the crossing itself highly visible and distinguishable from the surrounding road.
- Provide visibility of pedestrians at the crossing and through visibility (to ensure motorists are also aware of pedestrian activity beyond or in front of the crossing).  
To ensure that the approaching motorist clearly sees the place where pedestrians are to cross, the lighting must generate a defined luminous patch of light across the crossing carpet, with clearly delineated edges.

A mounting height of no more than 6 metres is usually most suitable to create this delineated carpet, while a different lamp colour from the surrounding road lighting is effective in helping highlight the carpet – for example neutral white light v warm white LED. Whereas LED lights are generally controlled by 35/18 photocells, **Cork County Council policy is to use 70/30 photocells for the auxiliary lighting on crossings, as the limited natural light at dusk/early morning can result in diminished visibility.**

Luminaires need to be as glare free as possible to ensure maximum visibility through the crossing area and generally the auxiliary lighting is fitted with right/left optics only to ensure the light is directed onto the pedestrian and not back on the motorist.

Supplementary lighting where provided will always be of the LED or Metal Halide type providing enhanced Colour Rendering ( $R_a > 60$ ).

These guidance parameters (explored in more depth in the ILP publication TR12) mean that the ideal pedestrian crossing luminaire will distribute most of its light in a concentrated pattern forward of the luminaire in a high enough beam spread to ensure that the complete height of the pedestrian is illuminated. The general parameters of TR 12 require the surface of the crossing to be illuminated to 3.5 x average horizontal with  $U_0$  of  $>0.6$  and an  $E_v$  of 2x nominal average horizontal road illuminance.

Road class (see also BS 5489-1:2003 table B1)	Carpet average (with 60% uniformity) [ Eave ] in lux	Centre and kerb edge grid minimum vertical illuminance [ Evmin ] in lux	Rear of waiting area grid minimum vertical illuminance [ Evmin ] in lux
CE1	105	60	45
CE2	70	40	30
S1	52.5	30	22.5
S2	35	20	15
S3	26.25	15	11.25
S4	17.5	10	7.5



**Low level lanterns located on both diagonals or**



**Zebra auxiliary lighting integrated into traffic signals**

An example of a suitable LED option for such low level intense lights are outlined below.

Luma micro lantern – with special optics

For a pole on the **Left** use the **Right** optic. **BGP615\_DPR1\_6000\_20LED\_5.1S\_CLO\_L90\_NW\_PT – NO DIMMING**

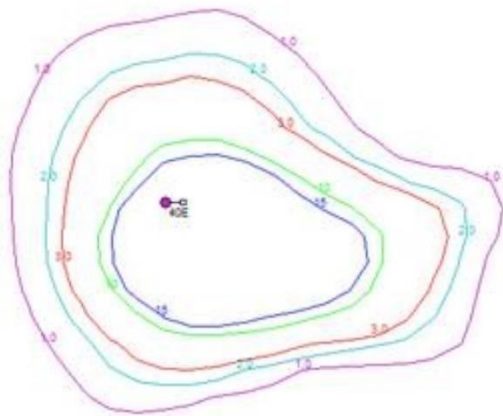

#### Luminaire E Data

Supplier	Philips
Type	BGP615_DPR1_6000_20LED_5.1S_CLO_L90_NW
Lamp(s)	LED-HB 5.1S NW
Lamp Flux (klm)	6.00
File Name	Luma Micro_BGP615_DPR1_6000_20LED_5.1S_CLO_L90_NW.ies
Maintenance Factor	0.87
Imax70,80,90(cd/klm)	247.8, 31.8, 0.0
No. in Project	1

For a pole on the **Right** use a **Left** optic. **BGP615\_DPL1\_6000\_20LED\_5.1S\_CLO\_L90\_NW\_PT – NO DIMMING**

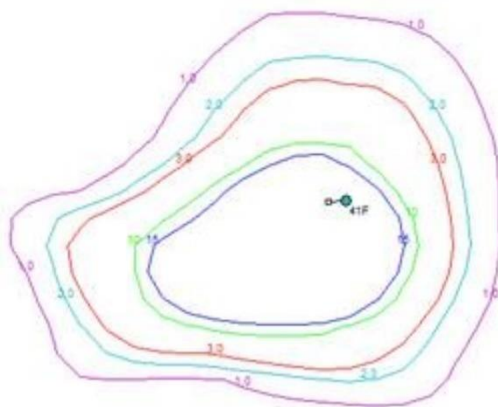

#### Luminaire F Data

Supplier	Philips
Type	BGP615_DPL1_6000_20LED_5.1S_CLO_L90_NW
Lamp(s)	LED-HB 5.1S NW
Lamp Flux (klm)	6.00
File Name	Luma Micro_BGP615_DPL1_6000_20LED_5.1S_CLO_L90_NW.ies
Maintenance Factor	0.87
Imax70,80,90(cd/klm)	247.8, 31.8, 0.0
No. in Project	1

Extra night time lighting is not as important at red/orange/green/pelican/toucan crossings as the traffic is more likely to stop on a red light but is an added safety measure where provided.

## **17. Temporary Lighting**

***In the cases where a Development will include for the replacement of an exterior lighting scheme Cork County Council require that a temporary exterior lighting scheme be installed whilst construction works are undertaken.*** Instances where this may be required include but are not limited to:

- Where building supported exterior lighting fittings are removed to facilitate the development;
- Where extensive excavations are likely on “brown field sites” or where demolition of existing buildings is taking place. (In this case Cork County Council and / or ESB Networks may deem that the risk of a live underground cable being excavated and damaged is high and arrange that the cable is isolated. In this case the Developer shall be responsible for the provision of temporary exterior lighting until such time as the new scheme is installed and commissioned.
- Relocation or temporary relocation of existing Public Lights.
- Flood schemes where a riverside boundary incorporating public lighting is being relocated or enhanced.

Temporary lighting installations must take account of section 704 of the National Rules for Electrical Installations pertaining to construction sites. Account also needs to be taken of the positioning and angles of temporary lights so as to minimize glare and prevent dazzling drivers and pedestrians.

***Note: Exterior Lights may only be removed with the permission of Cork County Council, through it's Public Lighting Engineer. The Developer shall, prior to removing an exterior light, commission into service and maintain operational, temporary lighting until such time as he replaces the removed light(s) with a new scheme. Failure to do this will likely result in the Developer being liable in the event of any Public Liability claim against Council where exterior lighting is cited as a contributing factor.***

***Replacement lighting shall utilise new lighting equipment and shall be designed to the appropriate standard and approved by Cork County Council Public Lighting engineer in advance of installation.***

## **18. Night Time Lighting of Buildings and Structures – Spotighting**

- Design proposals should meet Best Practice criteria to provide a “Low Brightness” approach to lighting thus ensuring that an energy efficient scheme can put in place from the outset;
- The design should be undertaken by a professional lighting designer or by the Lantern supplier.
- Selective highlighting of a building or feature should be considered as against floodlighting. It is often the case that far too much light is projected onto a building destroying an appreciation of its architecture. When carried out correctly, different aspects of a building will be lit with separate lighting to enhance such features.
- LED spotlighting can be programmed to apply different colours to a building façade to match various occasions, e.g. yellow for daffodil day etc.
- The choice of lamp type and colour temperature should be sympathetic to the building material being lit. Cork County Council favour the use of warm (2,700-3,000k) white lighting to illuminate historical buildings, statues etc.
- The Designer should avoid using a small number of high wattage, wide-angle luminaires which will flatten the façade and wash out its features;
- The Designer should avoid mounting fittings parallel to the building – improved modelling of buildings will usually be achieved by lighting at an angle;
- Daytime appearance of fittings and cable is an important consideration – if possible try to conceal fittings behind shrubs, trees or building features;
- Consider glare to people inside the building looking out through windows – down-lighting and spotlights or ground recessed fittings located at close-offset positions to the wall or building will usually avoid such glare;
- Where possible, spotlights or floodlights should be fitted with louvers and cowls to control the beam and avoid sideways light spill;
- It is important to ensure that beams do not cause glare to motorists or pedestrians.
- Ensure that beams do not spill over the roof or around the side walls as this will create light pollution or glare nuisance to neighbours;
- For schemes being proposed for church buildings, the feasibility of providing back-lighting of the Stained Glass windows could be considered if the particular feature is visible to the public

- Night time lighting of buildings should be limited to dusk to midnight unless located in a town center location likely to be occupied well after midnight.
- Building/monument lighting schemes should in general be designed to switch-on at dusk with photo-cell control and be switched off at mid-night using a time-clock or part night photocell.
- It is accepted that such lighting schemes can be modified to take account of changes recommended at the final installation stage as a result of on-site trials and therefore some details may have be confirmed at that stage;
- A visualization software suite shall be utilized to demonstrate the lighting scheme on submission of the design.
- Amenity lighting may also have to be considered at the design stage to compensate for glare and ensure safe access to the building after dark when the floodlighting is in operation;
- ***Cork County Council policy in relation to the illumination of monuments, castles, monasteries etc., in public areas, has a willingness to cover the post installation energy costs but not to take over the maintenance of such lighting installations, with the exception of those commissioned by and intalled by Cork County Council***

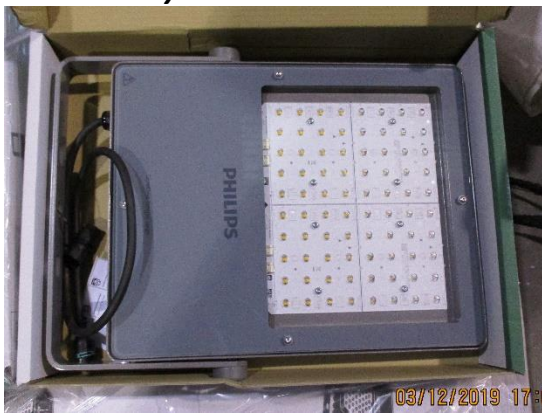

**Sample Spotlight for use on smaller structures**



**Sample Spotlight for use on larger structures such as Churches.**



## **19. Floodlighting Schemes**

Where floodlighting schemes for playing fields, pitches or courts etc. are being proposed by sports clubs, schools etc. it should be noted that these are subject to the planning process. Cork County Council has the following requirements in the implementation of such schemes:

- The energy efficiency of the proposed scheme must be central to the design process. The use of energy efficient floodlighting lamps and control gear is required. This will have obvious benefits to the scheme owners;
- The lighting should be designed by a competent lighting designer; this may include the use of the lighting suppliers in-house design service. Designs should be in accordance with BS EN 12193: 2018 Light & Lighting –Sports Lighting, European standards.  
The lighting design shall be submitted for approval.  
The designer shall aim to ensure that the scheme is neither under-lit nor over-lit for the type of sport being catered for. The selection of lighting Class shall be in accordance with table 4 of BS EN 12193:2018. Lighting Class I (*500 lux in the case of a rugby field*) is mainly reserved for International and National competition, which would not be applicable to the majority of schemes. Lighting Classes II and III would be more applicable in most situations. For example, a Rugby field lighting should aim for the order of 200 E<sub>hor Ave</sub> lx (class II), unless there was a likelihood of international matches and large spectator capacities with long potential viewing distances.
- ***The scheme designer shall demonstrate to Cork County Council by way of a design submission that minimizes light pollution, eliminates as far as is possible light spill into neighboring property and takes account of the “Campaign for Dark Skies”;***
- The scheme designer will aim to minimize or eliminate glare from the proposed lighting scheme which is likely to effect adjacent dwelling users or such that it would create a hazard to road users.
- The scheme designer shall take account of the location of the proposed scheme in relation to the requirement for an aircraft warning light on the top of the light support structure (e.g. in the case of high structures). In this regard the Irish Aviation Authority may need to be consulted;
- Account shall be taken pertaining maintainability of the scheme following commissioning including site access etc.
- The flood lighting scheme should incorporate the facility to cater for a reduced level of lighting for training as against that required for competition events in the interest of reducing energy consumption.
- Floodlights shall be in accordance with BS EN 60598-2-5.

- Schemes shall incorporate recommendations of ILP *Guidance Notes for the Reduction of Obtrusive Light GN01:2021* taking account in particular of spill light into domestic premises and designs shall be subject to the limits imposed at the appropriate Environmental zone.
- For sports complex floodlighting schemes, Applicant should demonstrate in planning application that ‘Reduction of Obtrusive light’ has been considered and should outline the mitigating measures proposed. Typically an Applicant will be required to submit
  1. A plot of lighting lux levels on an OSI background map at a maximum scale of 1:500 so as to allow an assessment of the light spill onto adjacent properties.
  2. That the floodlighting design shall take into account the ground level difference between the pitch / track and the gardens of the neighbouring properties and shall be in accordance with BS EN 12193-2018.
  3. A report outlining how light spill into adjacent properties is to be mitigated against to the limits outlined in Table 2 of the ‘BS EN 12193:2018 Light and lighting – Sports Lighting using Environmental zone appropriate to the location, inclusive of cross-sections demonstrating the projected lighting patterns from the masts onto adjoining affected properties pre and post the application of mitigating measures. Cross-sections should be a true reflection of ground levels, proposed within the development versus existing levels outside the development.

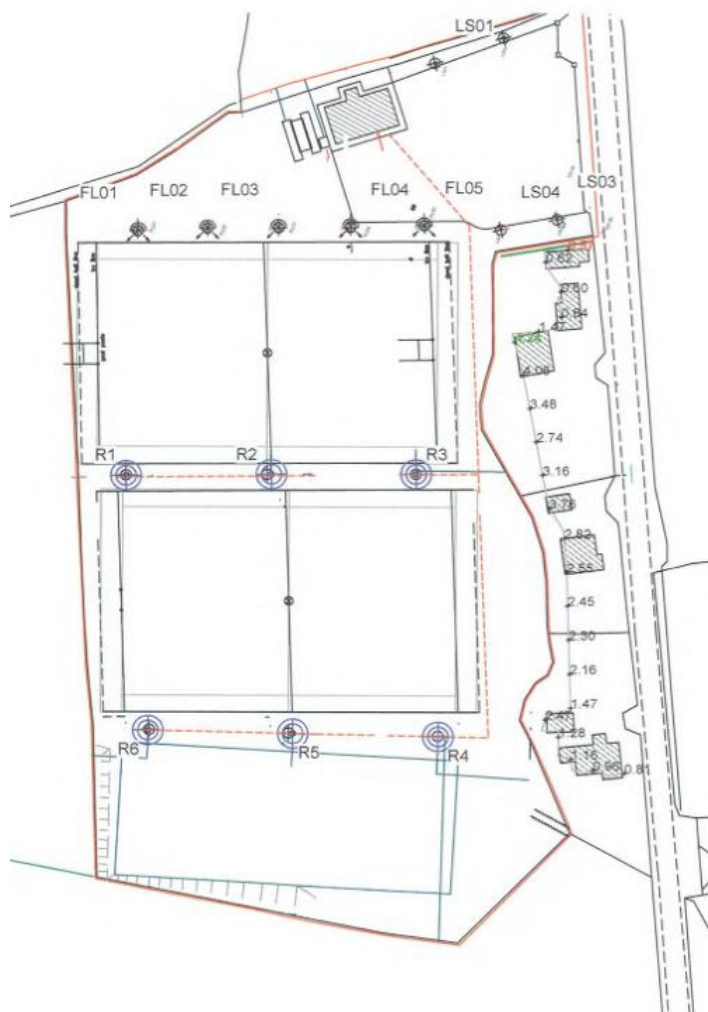

*Typical extract from report demonstrating compliance with max Ev*

4. If the floodlights are visible from a road, the Applicant is required to demonstrate compliance with Table 3 of EN 12193:2018 – Maximum values of threshold increment from sports lighting installation. This can be achieved by demonstrating that the threshold increment from the sports lighting does not exceed the values in Table 3, for the appropriate road lighting design class, at points along the roadway from where the floodlighting is likely to be visible. This can be demonstrated through Lighting Reality by creating an Illuminance Glare report.

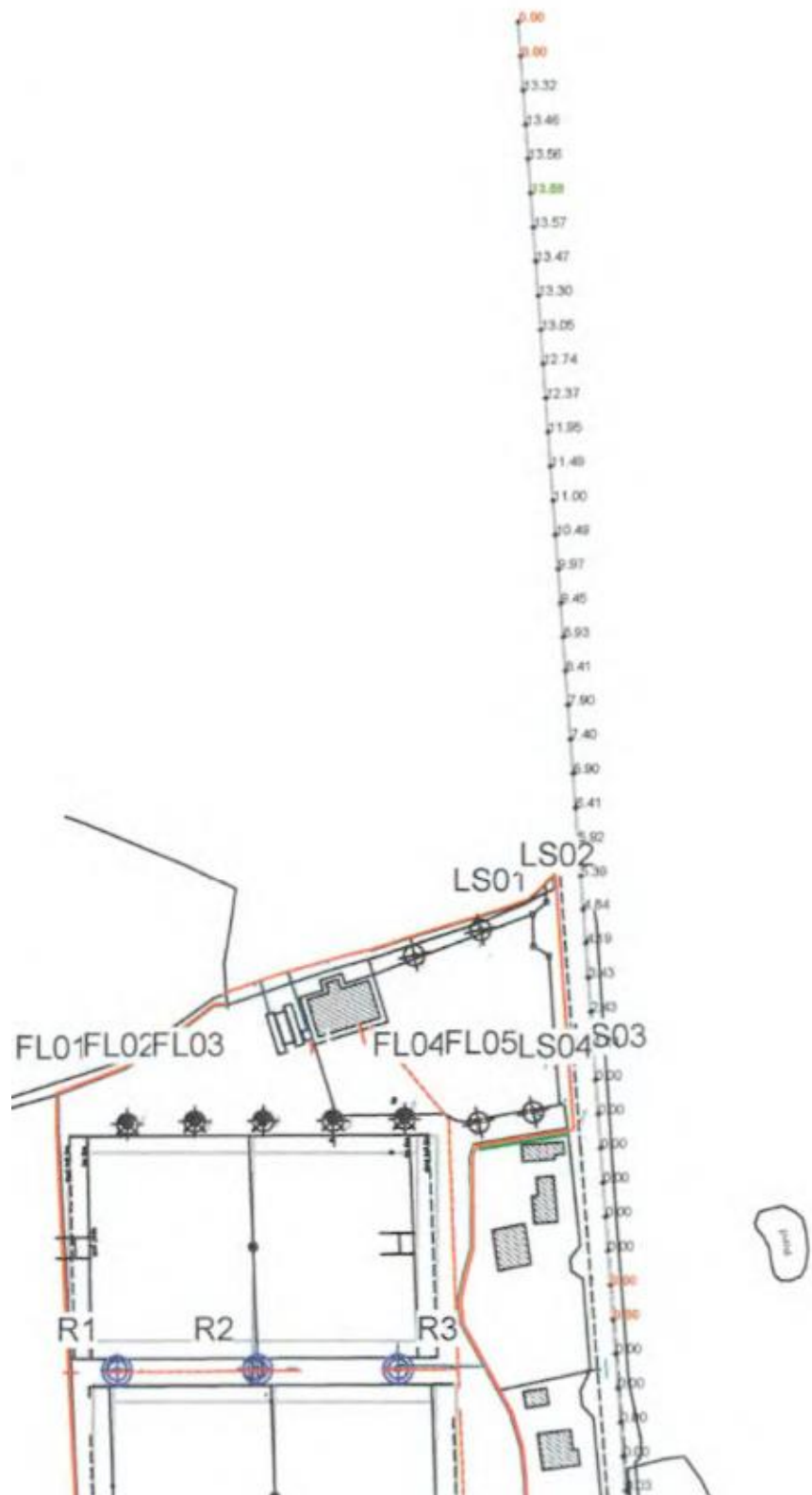

Typical extract from report demonstrating compliance with max fTI

5. A definition of **Threshold increment (TI)** states; *A measure of disability glare expressed as the percentage increase in contrast required between an object and it's background for the object to be seen equally well with a source of glare present.*  
**Care needs to be taken to ensure that glare is minimised by using lanterns at or close to zero tilt and at a sufficiently high elevation to achieve the desired light spread as an alternative to floodlighting installed at a lower level, relying on a lantern with significant tilt to throw the light for the extent required. The latter arrangement is much more likely to result in significant glare. The use of cowels and shields is also an effective way of mitigating against obtrusive lighting or unwanted glare.**
6. Below are typical planning conditions that are applied to applications for sports floodlighting.

No.	Condition	Reason
1	External Floodlighting within this development shall be designed in compliance with BS EN 12193:2018 and shall be directed and cowled/louvred as necessary so as not to cause any undue glare or additional light spill to adjoining residential properties, when assessed against maximum limits outlined in Table 2 of this standard applicable to Environmental zone E2. A curfew of 11 pm shall apply to the use of the floodlights within this complex.	In the interest of not interfering with adjacent dwelling owners.
2	Floodlighting within this development shall be directed and cowled as necessary (by the use of Louvres, cowls, hoods or shields) to restrict obtrusive light onto adjacent road(s) to the relevant threshold increment (fTI) limit detailed in Table 3 of BS EN 12193:2018, (Table 5 of ILP GN 01/20), applying to Road Class M5, in this instance.	To avoid creating a road hazard for motorists due to excessive glare from the Floodlights

*Typical planning condition applied to the Floodlighting of playing pitches/running tracks/tennis courts*

## **20. Urban Architectural/Heritage Street Lighting**

### **20.1**

Good quality lighting promotes a safer environment by ensuring inter-visibility between users. Poorly illuminated carriageways and cycle lanes can also make it difficult for users to identify potential hazards.

The quality of lighting will also have a major impact on perceptions of security. If lighting levels are not sufficient, a place may not be perceived as safe, particularly for pedestrians and cyclists. This may discourage people from walking and cycling, particularly in the winter months when days are shorter, and undermine the viability of public transport.

### **20.2**

The standards used for lighting within Ireland are generally taken from British Standard Code of Practice for the Design of Road Lighting (BS 5489). Whilst these documents should be referred to in regard to technical details, there are broader design considerations in regard to type of lighting used and the position and design of lighting columns.

### **20.3**

Lighting should be designed to ensure that both the vehicular carriageway and pedestrian/cycle path are sufficiently illuminated. On roads and streets within urban areas white light sources such as LED should be used. Where orange (SOX) or softer honey (SON) coloured lights are currently used, they should be replaced with warm white light LED's as part of any upgrade.

### **20.4**

Heights should be sensitive to the scale of the adjacent built environment.

In city, town and village streets, a lantern mounting height in excess of 8 metres may be required on wide streets but in general 8m high should suffice.

On Local roads/streets, and in areas of heritage significance, mounting heights should be no greater than 8 metres.

In housing estates, generally, 6m high columns will suffice.

Where higher numbers of pedestrians are active, such as in town centres, consideration should be given to supplementing the traffic route lighting installation with lower intensity (perhaps decorative) pedestrian lighting lanterns mounted at a lower height on the same columns, sometimes on the rear of columns located on the outside of the footpath.

### **20.5**

In many cases, especially where streets/plaza's are being pedestrianised, Architects seek alternatives to standard light columns and fittings. Most of the recognised manufacturers also provide alternative decorative/architectural type lights. The WE-EF brand which offers both traditional and modern alternatives is often the preferred choice of Architects and similarly other brands such as vfl are also used.



Samples of Light Types used in Cork County –to date



***Cork County Council do not favour the use of mini-photocells as they can be problematic and access to daylight can be blocked by something as simple as bird droppings.***



## 20.6

Lighting installations should generally be located within a verge and/or within build-outs that separate bays of on-street parking. They must be located on public ground.

Lighting columns must be at least 2m away from an ESB mini-pillar or a PL micro/midi pillar.

Where no verge is available, lighting should be located at the back of footways, to minimise any disruption to pedestrian movement provided:

They should be positioned, where possible to coincide with property party lines to avoid obstructing entrances or windows.

They should not be located in close proximity to properties where they may compromise Security.

On narrow streets or streets with narrow footways, consideration should be given to using wall-mounted lanterns.

Lanterns should be selected and positioned so as to avoid creating obtrusive light spill on windows, particularly in the case of upstairs residential properties. Internal or external baffle plates can be fitted to lanterns to minimise nuisance light spill.

Lights should also be positioned at least 10m away from trees, (on same side), which in time may grow to envelop the lanterns or cast shadows which will render the lighting less effective.

## 20.7

CCTV cameras require columns, which need to be more rigid than lighting columns and hence are not suitable for mounting on public lighting columns. There are also health & safety reasons for not allowing other items to be mounted on public lighting columns.

***Cork County Council do not allow CCTV or other non public lighting implements, to be attached to Public Lighting Units.***

***The electrical connection from Public Lighting micro/midi-pillars and the supply at Public Lighting Units cannot be used for any other purpose, other than Public Lighting.***

Ancillary lighting equipment, such as electrical supply pillars, should also be located with a view to minimising their impact on the streetscape, while not creating an obstruction or hazard to pedestrians.

Metering cabinets in particular, which may be up to 1.5 metres high, should be located against walls, as unobtrusively as possible, while bearing in mind that they must be accessible for maintenance and meter reading.

## 20.8

Uplighters installed in footpaths can be used to enhance the architectural features of significant monuments and public buildings during periods when there will be significant presence on the streets. ***They should not be intended for use as a practical lighting source.***



IP67 Rated Uplighter .Maintenance of uplighters can be problematic as they are easily vandalised.Should ideally only be used in decorative Town Square pedestrian areas or close to buildings for illumination of facades.

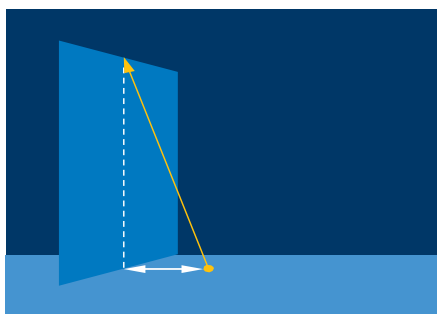

Uplighter Washing Building Façade.

## 20.9 Traffic Calming Gateway Lighting

In traffic calming schemes, the Gateway is generally placed at the start of the speed limited zone. It should mark a definite change in the character of the surrounding area from rural to urban. Therefore it needs to be conspicuous and the most prominent element in the transition zone. The tall signs positioned close to the driving lane narrow the optical width.

Gateways fall into two distinct groups, those with a solid kerbed central island and those with no island.

The gateway is always lit to a high standard, with special gateway lanterns that shine directly onto the gateway signs. This is not only effective in the dark; during daylight hours the presence of lighting columns enhances the narrow optical width and is often noted subconsciously by the driver as an indication of an urban area. This lighting can be affected either by creating a bright lighting corridor by erecting lights at either side, which also serve to enhance the night-time view of the gateway signs.





***Cork County Council (and now TII Guidelines) do not favour lighting standards in the centre of roads due to the obvious hazards they pose. Better to light from the sides.***

Gateway lighting using supplementary LED lighting on double-headed column in central island. These should be hinged and socketed to allow the column to be lowered for Abnormal Loads

## **21. Photovoltaic Lanterns (Solar Powered/wind assisted)**

With the arrival of low wattage LED type luminaires, specific applications such as the recreational area illustrated, can be lit by a “stand alone” column and lantern, where a battery charged by the photovoltaic cell provides enough energy to deliver several hours of lighting. A presence detection system ensures that wasteful use of light is avoided.

These type of lights are under development and possibly not yet at a sufficient stage for widespread use but could possibly be considered in one-off rural locations as an economic alternative to traditional lighting systems, or where dusk to midnight lighting is acceptable.

There are two types of solar powered lights. One incorporates the solar panel and battery within the body of the lantern.



*Typical solar powered lantern front and back images*

Typical outputs from this integrated type light are of the order of 2000 lm and would be typically used with a motion sensor to preserve charge.

Generally, there is a 10 year warranty on the Solar lantern and a 5 year warranty on the battery, which has a design life of 5.5 yrs, though solar powered lights with higher output and longer battery life ( up to 8 yrs) are under development.

Cork County Council carried out a pilot solar powered project in 2022 at Ballynoe, near Fermoy using 2 klm Philips Sunstay Lights on a quiet rural road leading out of the village. First impressions were that they give good light, even in their dimmed state but the light output ramps up when activated by the PIR sensor.

The lights were checked at 11.30 pm on a November night and were found to be still providing a reasonable level of light but when checked again at 7am, all had extinguished. This is not unexpected due to the short days at that time of year and it can be expected that they are likely to last for the full hours of darkness in Spring/summer/Autumn, when pedestrians are more likely to be out and about.

Passing traffic ( though low in volume) was setting the lighting to ramp up and hence it is unlikely that they would last as long on a road with higher traffic volumes and ***hence their use would be better confined to off -road walkways/cycleways, car parks and Town parks for the moment.***

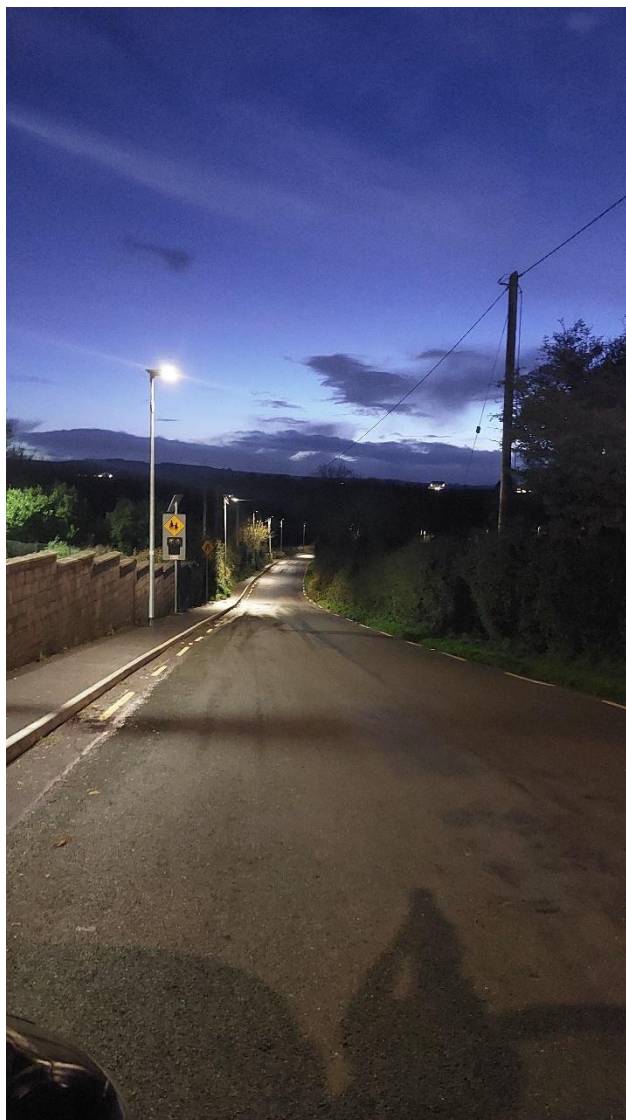

*Lighting output at 5.30 pm on a November evening*



*Situation at 11.30 pm on Winter night*

Using Lighting Reality we have determined that for the installation of 2 klm Solar Sunstay lights on a 5m road with 2m footpath, nearside, the maximum spacing required of of 6m high lanterns would theoretically be;-

26.5m to achieve P4,  
17.5m to achieve P3.

New generations of solar lighting currently under development will have larger batteries and higher lumen outs which will allow greater gaps to achieve the same standards.

Another type of solar powered lantern, which gives higher output incorporates a separate solar panel, typically mounted on top of the column and a significant battery pack contained in a secure box, usually located towards the base of the column.





A further option combines solar power with wind power to typically output to a 35w LED Unit with integral Photocell & occupancy sensor , designed for instant start & delayed switch off after occupancy detection. In this option, the solar panel typically contributes 80w and the wind turbine 200w.

**Construction:** Typically an 8m flanged octagonal pole with turbine, solar panel and luminaire. Batteries are stored in a separate box at base of pole.



In the Northern Hemisphere it is challenging during winter daylight hours to sufficiently charge batteries so that they will be capable of powering lights from dusk to dawn (16.5 hours approx on 21<sup>st</sup> December).

Initial investment is higher compared to conventional street lights but when compared to the cost of installing ducting, cabling etc. then the unit rate for the erection of a solar light works out at about half to two thirds of the cost of an electrically powered light served by underground services. Obviously, a light fitted to an existing ESB pole still rates as the cheapest capital cost of lighting provision at about 1/3<sup>rd</sup> the unit cost of a solar light. However, rechargeable batteries will need to be replaced several times over the lifetime of the fixtures (currently approx.. € 300 each) adding to the total lifetime cost of the light.

***Cork County Council policy is not to allow such lighting as an alternative to lighting fed from an electricity supply except in exceptional circumstances where the prior approval of the Public Lighting Engineer has been achieved. Perhaps at small scale remote piers remote car parks and potentially on the more rural elements of greenways etc.***

The next big energy saving methodology, post LED retrofitting, may be hybrid lights, which would always have a constant light output, but which would derive up to 70% of their energy requirement from solar and 30% from 230V supply. However, there is discussion required with UMR in first instance to see how unmetered hybrid lights would be paid for from an energy perspective. On a metered supply, the savings would be automatic.

## **22. Documentation required with planning applications involving Public Lighting**

***Cork County Council requires that Public Lighting be designed by a competent Public Lighting Designer proficient in the use of Public Lighting Design Software. 'Lighting Reality' is the preferred software but designs to other software packages may also be acceptable. The design report should include a schedule of the lights to be installed as well as details of each luminaire type. (see sample in Appendix H, Figure 2)***

***Lanterns shall be LED type, (generally warm white) using brands commonly used in, and acceptable to, Cork County Council. If in doubt, the designer should contact the Council's Public Lighting Engineer, (022-30472).***

Street lighting designs should be submitted to Cork County Council for approval via the Planning application procedure in accordance with Appendix H.

***The Public Lighting design/layout will be vetted by the Public Lighting Engineer and shortcomings will either be referred back to the applicant to address.***

***Note that Cork County Council have a preference for more lights of lesser intensity rather than less lights of higher intensity, as the latter can lead to a 'zebra effect' of bright/dark/bright, which is undesirable. In particular, on relatively short branch roads/cul-de-sacs, twin lights of lesser intensity are preferred to singular lights of high intensity designed to barely reach the extremities. The use of high output lighting in housing estates can lead to glare and obtrusive lighting issues in a location where softer lighting is desirable so as not to affect residents sleep patterns.***

***When designs are deferred for more information/clarification, Cork County Council's PL department are open to discussing alternate designs before they are re-submitted for approval as part of the planning process.***

The planning application documents required to vet the Public Lighting element should comprise of the following requirements at a minimum;

1. An Exterior Lighting Design Report (preferably, Lighting Reality, see typical example in Appendix H, Figure 1 & Figure 2). This report should state the design class and associated parameters and should demonstrate how these parameters have been achieved. It should also provide details of the proposed lantern(s) and column types etc.
2. If different elements of the development are to be designed to different lighting classes, then a separate grid should be outlined within the PL design report outlining that the appropriate Class design standards have been achieved, within that grid.
3. Lighting layout drawings to a scale of at least 1:500, on a scheme layout background on either A0 or A1 or A2 drawing (depending on the development

size, but preferably all on one drawing), inclusive of a plot of lux contours showing the minimum lux level, 3, 5, 10, 15, 20...lux, as appropriate. In the case of a development with elements designed to separate classes, the lux drawings should be combined in a single layout drawing.

4. The lux contour lines shall be of a colour and intensity that makes them easily identifiable from the background road/boundary/ducting lines and individual spot lux levels shall be omitted from the drawing to avoid clutter. The lux contours should be such to demonstrate that the minimum design lux level (Emin) has been achieved in all locations where lighting is required. In Floodlighting situations the lux contours must not be cut off at the boundary of the site as they are required to assess the likely light spill into adjacent properties. The background drawing must clearly outline the features of the proposed development so that the Assessor can check that all necessary element of the site layout are adequately lit.
5. In general, all roads and footpaths, within an estate are required to be lit inclusive of any amenity walks that can be used to access/egrees the estate. In general, play areas are not required to be lit, except those locations where outdoor gym equipment is provided as these could be in use after dark. Car parking areas and hammerheads at the ends of cul-de-sacs need to be adequately lit. The entrance to the site from the public roads needs to be lit to a high standard and generally the road curtilage of the site will be required to be lit if such lighting does not exist currently. In general, any gaps to the Town/Village lighting scheme will need to be addressed either by the Developer installing such gap lighting or by Special Planning Contribution, though the former is preferred.
6. The applicant shall either include proposed tree locations on the Public lighting drawing to demonstrate that no trees are to be planted within 10m of a public light or vice-versa shall impose the public lighting locations on the Landscape drawings with a 10m radius circle around each light to demonstrate that the clear zone wont be breached by tree foliage.
7. The applicant shall aim to site public lighting columns in public ground, and where appropriate columns shall be located on the boundaries between properties and not in locations where could affect the potential to extend driveways in the future.
8. Appropriate Standard Construction Details (SCD's);
9. Details of proposed Lanterns, brackets and columns.
10. The requirements associated with applications involving floodlighting are further expanded on within Chapter 19 of this document.

## **23. Taking in Charge**

The taking in charge of a lighting scheme is the procedure whereby the Developer shall satisfy Cork County Council and the DSO (ESB Networks) that the scheme conforms to the ETCI National Rules for Electrical Installations and the Developer shall also satisfy Cork County Council that the layout and levels of lighting conforms to the CEN Code of Practice and BS standards.

The Electrical Contractor shall provide a Completion Certificate for the exterior lighting scheme and shall be responsible for progressing the application for supply. The customer's copy of the electrical certificate (RECI) shall be retained and submitted to Cork County Council at the taking-in-charge stage.

The taking in charge of Public Lighting in Estates is usually completed in conjunction with the full TIC of an estate or a completed phase. However, in certain limited circumstances Cork County Council may consider taking the lights in charge in advance of full takeover, where the estate (or a definitive part of) has been virtually completed, the lighting is up to standard and the partial take-over is recommended by the Council's Estates Engineer.

The taking in charge procedure of Cork County Council is administered by the Estates & Development/Planning Directorate of Cork County Council.

Cork County Council requires that the Exterior Lighting Scheme be maintained operational and in the same condition as it was when the snagging list was completed up until the date that the estate is formally taken in charge.

Cork County Council will also require that each column and customer service pillar installed shall have a label attached with a numbering scheme agreed with the Developer at the taking in charge stage. This is to allow for maintenance coordination, column / luminaire identification and recording of the individual column in Cork County Council's Exterior Lighting Asset Management Database.

The readiness of the Public Lighting, for takeover is determined by a 'taking in charge survey' carried out by the Council's Public Lighting maintenance contractor and Public Lighting Engineer. Ideally, it is the Developer who should engage the service of the Council's Maintenance contractor to carry out the survey and to overcome any shortcomings before presenting a satisfactory TIC report to the PL Engineer.

The Applicant is also required to list/demonstrate on a drawing, the lights (and their numbers) that are connected to each individual micro/midi-pillar.

The taking in charge request form for the public lighting element is available on the Cork County Council website ([www.corkcoco.ie/publiclighting](http://www.corkcoco.ie/publiclighting)). The current version is contained in Appendix B of this document. A Developer wishing to have a exterior lighting scheme taken in charge for energy and maintenance shall complete this form and submit it to Cork County Council, Estates and Development Directorate, along with the following;



- RECI cert for the lights to be taken in charge, in paper and electronic format.
- Public Lighting Design Report (Lighting Reality) and Public Lighting Layout Drawings, associated with the development.
- As –built drawings of the Housing Estate/Development showing the position of columns (incl. Col. Nos.), micro/midi pillars, ducting Layout, power supply location and circuits from each power source indicating which lights are connected to which supply point.
- Details of any warranties (inclusive of expiry dates) associated with component parts.
- Details of each Light in accordance with SEAI/CCMA Standardised Public Lighting Inventory Template excel spreadsheet attached in as much detail as possible.
- General date of installation of Public Lighting (year)
- Circuit drawings and fuse details
- An energy supply bill showing the MPRN('s) associated with the development and demonstrating that the account up to date. ***Cork County Council will not be responsible for any arrears on energy costs which pertain the period in advance of the transfer date of the account post the taken-in-charge date.*** The Council will arrange the transfer of the MPRN('s) within the development to the Council's Public Lighting GMPRN, which usually occurs on the 1<sup>st</sup> of the month following the transfer.

On receipt of the completed forms Cork County Council, Roads (Public Lighting) Division, will either instruct the Applicant to engage Cork County Council's Public Lighting Maintenance Contractor to undertake an inspection of an exterior lighting scheme or in limited circumstances, will arrange this itself. On foot of such inspection, a Report is issued to Cork County Council by the Maintenance Contractor. A typical TIC Report form is contained in Appendix C.

In addition, the site will be visited by the Public Lighting Engineer to review non-electrical/structural aspects such as the appropriateness of the spacings and to check whether lights and micro/midi-pillars are located on public ground. The PL Engineer will also compare the actual layout against the Planning Drawings to ensure compliance.

Any snags required to be completed to bring the installation to an acceptable standard will be communicated to the applicant and the process will be repeated until a satisfactory conclusion has been achieved.

When the Developer confirms that the snagging list has been completed, a further inspection(s) will be undertaken and the process will be repeated until a satisfactory conclusion has been achieved.

When The Public Lighting Engineer confirms that the exterior lighting scheme is in a suitable condition to be taken in charge, The Council's Planning Directorate shall inform the

Developer by means of a formal letter indicating the date on which Cork County Council will assume responsibility for the services within the development or part thereof.

***The Developer is to ensure that energy costs and any arrears are paid, right up to the date on which the development is taken in charge and for the period thereafter until the energy account has been taken over.***

***Cork County Council will assume responsibility for the payment of the Energy bill from the date on which the MPRN's are transferred across to the Council's GMPRN for lighting, which usually occurs on the 1<sup>st</sup> of the month following the request for transfer. It will not be responsible for any arrears on the bill in advance of that date.***

## **24. Conclusion**

Cork County Council reserves the right to ensure that exterior lighting schemes are designed and installed to the required standards/Codes of Practice before agreeing that the scheme can be taken in charge.

Cork County Council and their public lighting Unit wish to work with Developers and their lighting design specialists to help deliver high quality, energy efficient, exterior lighting installations which meet the relevant standards and which improve the general ambiance of the county and help to reduce energy and carbon consumption.

Cork County Council,  
Public Lighting Department  
Annabella,  
Mallow,  
County Cork  
Phone: 022 30472  
Email.  
[Publiclighting@corkcoco.ie](mailto:Publiclighting@corkcoco.ie)

## References

1. Institute of Lighting Professionals of UK & Ireland [www.theilp.org.uk](http://www.theilp.org.uk)
2. BS EN ISO 1461: 2009 Hot dip galvanized coatings on fabricated iron and steel articles.
3. IS EN 40-1:1992 – Lighting Columns. Definitions and terms.
4. IS EN 40-2:2004 - Lighting Columns. General requirements and dimensions.
5. IS EN 40-3-1:2000 - Lighting Columns. Design and verification. Verification by testing.
6. IS EN 40-5:2002 - Lighting Columns. Requirements for steel lighting columns.
7. BS PD 6547:2004 - Guidance on the use of BS EN 40-3-1 and BS EN 40-3-3
8. IS EN 1991-1-4:2005 – Eurocode 1: Part 1.4 Basis of design and actions on structures. Actions on structures. Wind Actions.
9. BD 94/07 – DMRB Vol. 2 Highway Structures Design (Substructures and Special Structures), Materials. Section 2 Special Structures Part 1 BD 94/07 Design of Minor Structures (Formerly BD 26/99 & 26/04)
10. NRA BD 26/04 - NRA Addendum to BD 26/04.
11. BS 5489-1:2013: Code of Practice for the design of road lighting. Part 1: Lighting of roads and public amenity areas.
12. EN 13201-1:2014: Road Lighting – Part 1: Selection of lighting classes.
13. EN 13201-1:2014: Road Lighting – Part 2: Performance Requirements.
14. EN 13201-1:2014: Road Lighting – Part 3: Calculation of performance.
15. EN 13201-1:2014: Road Lighting – Part 4: Methods of measuring lighting performance.
16. ESB National Code of Practice for Customer Interface 5<sup>th</sup> Edition 2021.
17. BSEN 60598-1:2008. Luminaires General requirements and tests.
18. IET Code of Practice for the application of LED lighting systems 2014
19. ESB Housing Schemes Electrical Services Standards Guidebook Revision 3 Nov 2012.
20. ESB Code of Practice for avoiding danger from overhead electricity lines 2008.
21. ESB Requirements for Work on Public Lighting on ESB's Networks 2020.
22. HSA Code of Practice For Avoiding Danger From Underground Services Second Edition January 2010. [www.hsa.ie](http://www.hsa.ie)
23. ILP Professional Lighting Guide 02. The Application of Conflict Areas on The Highway. [www.theilp.org.uk](http://www.theilp.org.uk)
24. ILP Professional Lighting Guide 03. Lighting For Subsidiary Roads. Using white light sources to balance energy efficiency and visual amenity. [www.theilp.org.uk](http://www.theilp.org.uk)
25. ILP Professional Lighting Guide 07. High Masts For Lighting and CCTV (2013 Edition). [www.theilp.org.uk](http://www.theilp.org.uk)
26. ILP Technical Report 12 TR12 Lighting of Pedestrian Crossings ILP Technical Report 30. Passive Safety: Guidance on the Implementation of Passively Safe Lighting Columns and Signposts. [www.theilp.org.uk](http://www.theilp.org.uk)
27. ILP Guidance Notes for the Reduction of Obtrusive Light GN01:2020. [www.theilp.org.uk](http://www.theilp.org.uk)
28. ILP Code of Practice for Electrical Safety in Highway Electrical Operations [www.theilp.org.uk](http://www.theilp.org.uk)
29. IS 10101:2020 National Rules for Electrical Installations.
30. Department of Transport ,Tourism,&Sport Design Manual for Urban Roads &Streets 2013
31. Department of Transport Traffic Management Guidelines 2003.
32. NRA Pedestrian Crossing Specification & Guidelines April 2011.
33. SHAWW Act 2005, SHAWW (General Application) Regulations 2007
34. IEC 62717: 2014 LED modules for general lighting - Performance Requirements
35. IEC 62722-2-1 Luminaire performance - Part 2-1: Particular requirements for LED luminaire.
36. DTTAS Guidelines for Managing Openings in Public Roads Second Editions April 2017
37. Design of Road lighting for the National road Network– TII Publications, DN-LHT-03038 August 2018
38. RMO Public Lighting Retrofitting Guidance Document – 2019

*Acknowledgements*;- The original inception of this document was prepared for Cork County Council in 2014, by James Molloy, (RIP) B.E. Elec., C. Eng., Member of the Institution of Lighting Professionals (MILP).

Fiona Fitzgerald, B.E. (Electrical), C.Eng, of MWP endeavoured to ensure that the most up to date references to ESB standards were correct at the time of publication of this version, but it is up to each user of this document to verify the latest version of any electrical standards referred to in this document.

## Glossary of basic Terms

<i>Candela</i>	Candela is the unit to express luminous intensity.
<i>Colour Impression</i>	Colour impression expresses the observer's perception of the light, e.g. golden white, warm white, cool white, yellow, etc. The colour impression can be chosen to suit the atmosphere of a specific area
Colour rendering	This parameter expresses the extend to which artificial light is able faithfully to render "true" colours of objects. Unlike in the city centres, in residential areas fair colour rendering is usually sufficient, except in areas, where crime risk is high.
<i>Glare</i>	Glare is the effect of strong bright light sources in the field of view. It can cause a feeling of unpleasantness but may even impair the visual performance and thus traffic safety. Care must be taken to limit glare as much as possible. However, a certain amount of sparkle can be desirable in pedestrian areas
<i>Illuminance.</i>	Illuminance is the luminous flux (i.e. quantity of light produced by the lamp), per unit of surface. It is expressed in LUX (lumen per square meter) <sup>(8)</sup>
<i>Longitudinal Uniformity (U)</i>	If a road is illuminated very unevenly, the driver perceives a series of bright and dark bands on the road surface. The light parameter used to describe this effect is longitudinal uniformity, and is the ration of minimum to maximum road surface luminance on a line which is parallel to the axis of the road and which passes through the position of the observer
<i>Lumen</i>	Lumen (lm) is the unit in which luminous flux (i.e. quantity of light produced by a lamp) is expressed
<i>Luminance</i>	the luminance of a surface is a measure of the brightness with which the surface is perceived by an observer. It is expressed in CANDELA PER SQUARE METRE (cd/m <sup>2</sup> ) the luminance of the road surface plays an important role in the visibility of objects. The better the reflection property of the road surface, the more light will be reflected and the brighter the road surface will appear
<i>Luminous efficacy</i>	The luminous efficacy is a measure of the rate at which a lamp is able to convert electrical power into light, and is thus expressed in lumens per watt. (lm/W)
<i>Luminous Flux</i>	The luminous flux is the quantity of light produced

by a lamp. It is expressed in the unit LUMEN (lm)

*Luminous intensity*

Luminous intensity is a measure of how the luminous flux is emitted in a certain direction. It is expressed in CANDELA (cd)

*Luminous Intensity Distribution*

The luminous intensity distribution is the pattern in which a luminaire distributes the luminous flux of a lamp. As most luminaires do not distribute the luminous intensity in a symmetrical pattern, the luminous intensities are measured in different planes.

*Overall Uniformity ( $U_o$ )*

Overall uniformity is the ration of the minimum to the average luminance of the road surface. It its value is too low, the visual performance decreases which has a negative effect on road safety

*Surround ratio*

The ratio between the illuminance on two 5m wide strips either side of the edge of the carriageway.

## Appendix A

### The Ingress Protection (IP) System of Classification

Two tables shown here list degrees of protection certified for different sizes of solid bodies and type of moisture. For example a light classed as **IP65** offers level 6 protection against the Ingress of Solid Bodies and level 5 protection against moisture.

**Table 1 – Degree Protection Against Ingress of Solid Bodies.**

<b>First Characteristic Numeral</b>	<b>Degree of Protection And Short Description</b>	<b>Details of Solid Objects which will be Excluded From Luminaire.</b>
0	Non Protected	No Special Protection
1	Protected against solid Objects greater than 50mm	A large surface of the body, such as a hand, (but no protection against deliberate access); Solid objects Exceeding 50mm in diameter.
2	Protected against solid Objects greater than 12 mm	Fingers or similar objects not exceeding 80mm in length; Solid objects exceeding 12mm in diameter.
3	Protected again solid Objects greater than 3.5mm	Tools, wires etc, of diameter or thickness greater than 2.5mm; Solid objects exceeding 2.5 mm in diameter.
4	Protected against solid Objects greater than 1.0mm	Wires or strips of thickness greater than 1.0mm; solid objects exceeding 1.0mm in diameter.
5	Dust Protected	Ingress of dust in not totally prevented but dust does not enter in sufficient quantity to interfere with the satisfactory operation of the equipment
6	Dust tight	No ingress of dust.



**Table 2 – Degree Protection Against Ingress of Moisture.**

<b>Second Characteristic Numeral</b>	<b>Degree of Protection And Short Description</b>	<b>Details of the Protection from moisture provided by Luminaire</b>
0	Non Protected	No Special Protection
1	Protected against dripping water	Dripping Water (vertically falling drops) shall have no harmful effect.
2	Protected again dripping water when tilted up to 15°	Vertically dripping water shall have no harmful effect when the Luminaire is tilted at any angle up to 15° from its normal position.
3	Protected against Spraying Water	Water falling as spray at an angle of up to 60° from the vertical shall have no effect.
4	Protected against Splashing water	Water splashed against the enclosure from any direction shall have no harmful effect
5	Protection against water jets	Water projected by a nozzle against the enclosure from any direction shall have no harmful effect.
6	Protected again heavy seas	Water from heavy seas or water projected in powerful jets shall not enter the luminaire in harmful quantities.
7	Protected against the effects of immersion	Ingress of water in a harmful quantity shall not be possible when the luminaire is immersed in water under defined conditions of pressure and time
8	Protection against submersion	The equipment is suitable for continuous submersion in Water under conditions which shall be specified by the manufacturer.

## Appendix B – Taking in Charge Application Form



COMHAIRLE CONTAE CHORCAI

CORK COUNTY COUNCIL

### Application Form for taking in charge Public Lighting \_\_

#### General Information

1. Developer's Name: \_\_\_\_\_
2. Developer's Address: \_\_\_\_\_
3. Telephone No. \_\_\_\_\_ 4. Email Address: \_\_\_\_\_
5. Planning Ref. No. \_\_\_\_\_
7. Name of Housing Estate/Road: \_\_\_\_\_
8. Address: \_\_\_\_\_
9. No. of Housing Units: \_\_\_\_\_
10. Energy Supplier: \_\_\_\_\_
11. A/C Name & No. \_\_\_\_\_

#### MPRN Information (1<sup>st</sup> MPRN)

12. (T)MPRN No. \_\_\_\_\_
13. No. of Lights: \_\_\_\_\_ 14. Lantern Type & Wattage: \_\_\_\_\_

**2<sup>nd</sup> and subsequent MPRN information should be provided where applicable on a separate sheet**

#### **The following documents are required to be submitted with the application:**

- RECI cert for the lights to be taken in charge, in paper and electronic format.
- Public Lighting Design Report (Lighting Reality) and Public Lighting Layout Drawings, associated with the development.
- As-built drawings of the Housing Estate/Development showing the position of columns (incl. Col. Nos.), micro/midi pillars, ducting Layout, power supply location and circuits from each power source indicating which lights are connected to which supply point.
- Copies of recent energy bill, including evidence that indicates that payments are up to date.

- Details of any warranties (inclusive of expiry dates) associated with component parts.
- Details of each Light in accordance with SEAI/CCMA Standardised Public Lighting Inventory Template excel spreadsheet attached in as much detail as possible.
- General date of installation of Public Lighting (year)
- Circuit drawings and fuse details

***Note: Cork County Council will only take over street lights in occupied sections of a housing estates and provided that the lights in question do not constitute part of an MPRN. (i.e. if an MPRN contains some lights within occupied section and some lights in unoccupied section, Cork County Council will not take over any of the lights associated with that MPRN until all of those lights are within a section that is occupied).***

Applicants acknowledge that any lights requested for taking-in-charge will be inspected by the Council's Public Lighting maintenance Contractor in advance and only schemes which are up to standard will be taken in charge. Otherwise the process will revert back until the lights are deemed to have been brought up to standard, by the Applicant.

Signed: \_\_\_\_\_  
Developer

Date: \_\_\_\_\_

Completed Application Forms for Housing Estates should be returned to:  
Estates Section, Planning Department, Co. Hall, Cork - for North & South Cork Divisions and Estates Section, Planning Department, Norton House, Skibbereen – for West.

*Completed application forms for new lights/schemes on public roads shall be returned to the Public Lighting Engineer, Cork County Council, Annabella, Mallow, Co. Cork.*

**Fig 1 : Cork County Council minimum data requirements per light**

Data item (extracted from SEAI Attributes, Nov 2015)	Data inserted by Applicant	Explanation
1) Street name/address		Name of Housing estate / Street name and address
2) Road No. if on public Rd.		e.g. L 1234
4) Village, Town or District		e.g. Mallow
6) Unit Owner		Name of payer of Energy Bills
7) TII Lighting Unit		Yes/No. (Yes if on a national Route
10) Unit Number		Tag Number on light
11) Unit Type		This is the type of structure used to mount the luminaire, e.g. column / wall mounted
12) Unit Co-ordinate northing		ITM (Irish Transverse Mercator) format
12) Unit Co-ordinate easting		ITM (Irish Transverse Mercator) format
16) Column Cross-Section		Style and shape of the column. Generally octagonal tapered.
17) Col Height		above ground level, generally 5m, 6m, 8m, 10m or 12m.
18) Column Material type		e.g. steel/aluminium/cast iron/wood.
18) Column base type		e.g. Rooted or flanged
21) Column installation date		To the nearest year
23) Bracket Material		e.g. steel, aluminium, cast iron
24) Bracket Type		integral/demountable
25) Bracket Dimensions		e.g. pole to, xm up and ym out.
26) Number Brackets		usually single but some cols have 2 or more
27) Bracket Tilt		e.g. 0, 5, 10, 15 degrees tilt.
28) Luminaire Height		Height of luminaire above ground, e.g. Col ht + bracket height. (or Can be measures
29) Number Luminaires		Usually only one but a high mast could have up to 12
30) Luminaire Installation date		As accurate as is available but to nearest year will suffice
31) Luminaire manufacturer		e.g. Philips, Thorn, Cree, Urbis etc.
32) Luminaire model		e.g. Luma 2, Civiteq etc.
35) Luminaire warranty expiry date		
36) Colour Temp		e.g. warm white/neutral white and actual kelvin setting if available.
38) Lumen output		e.g. 5,000 lumens
39) Lamp Type		e.g. LED, SON, SOX etc.
40) Wattage		nominal lamp wattage
42 & 43 Lighting Control & Location		e.g. photocell/time clock and individual/grouped
56) Interface Box		applies to lights on ESB poles / wall mounted mainly.
60) Passive safe column		Yes/No
62) Passive safe disconnection type		Electronic/mechanical/fuse
74) ESB Pole		Is light on an ESB pole Yes/No
75) Alert Pole		Applies to ESB poles
76) Over/Under		Is bracket an over/under conductor type
90) Lighting standard design		Design Class, e.g. P3 with S/P, M3, C4
96) Billable wattage		Applies to unmetered. Same as 40) if LED
99) Switching Regime		e.g. 35/18 or 70/30
101) co-ords of supply point E		of micro-pillar or connection point
102) co-ords of supply point N		of micro-pillar or connection point
103) Metered /Unmetered		
104) Current GMPRN		
105,106) TMPRN /MPRN		

**Appendix C**  
**Sample Taking in Charge Report Form**

<b>PUBLIC LIGHTING PRE-TIC INSPECTION CHECKLIST</b>			
General Information - Cover Sheet			
Estate Name:			
Address			
Developer Name			
Planning Ref:			
Inspection Requested by		MPRN or GMPRN:	
Inspected by:		Date of Inspection:	
Number of Public Lights in Estate			
Number of Pillars in Estate			
Is the Distance Between Columns Acceptable	Yes <input type="checkbox"/>	No <input type="checkbox"/>	
Columns Accessible with Hoist?	Yes <input type="checkbox"/>	No <input type="checkbox"/>	
Are Columns Numbered:	Yes <input type="checkbox"/>	No <input type="checkbox"/>	
PL Cable Size / Type (SWA/NYCY):		Flex Size / Type:	
Night Survey Carried out?	Yes <input type="checkbox"/>	No <input type="checkbox"/>	
All Lights Operational	Yes <input type="checkbox"/>	No <input type="checkbox"/>	
Supply Type	METERED <input type="checkbox"/>	UNMETERED <input type="checkbox"/>	
<b>Overall Summary of work necessary to be done prior to TIC by CCC: (Costing to be provided on a seperate sheet)</b>			
<b>Sign Off and Approval:</b>			
Signed and dated by Inspection Electrician:			
Print Name of Inspection Electrician:			
Checked, Signed and dated by Manager:			
Print Name of Manager:			

PUBLIC LIGHTING PRE-TIC INSPECTION CHECKLIST				
Estate Name:				
Address				
<b>Lighting Information</b>	Page:		Of	
Item.	Pillar Reference No.			
<b>Pillars</b>				
MCB / Fuse - Type / Size:				
MCB / Fuse Acceptable (Y/N):				
Bonding/Earthing acceptable (Y/N)				
Pillar Condition acceptable (Y/N)				
Remedial Action needed (if any):				
Item:	Pole / Column Reference No.:			
<b>Poles / Columns.</b>				
Material & Manufacturer (if known):				
Hinged / Standard				
Foundation Type: (Rooted / Flanged)				
Height. (Meters)				
Type (Hex./Round)				
Fuse Type / Size:				
Fuse Acceptable (Y/N)				
Bonding Acceptable (Y/N)				
Door Type (Single/Double Fixing):				
Energised (Y/N)				
Interface Box. (Y/N)				
Remedial Action needed (if any):				
<b>Lanterns.</b>				
Manufacturer:				
Model:				
Type: (Soc/Sox/Led)				
Wattage:				
Remedial Action needed (if any):				
<b>Photocells:</b>				
Manufacturer:				
Model:				
Switching Ratio (D/D, D/M)				
Condition:				
Remedial Action needed (if any):				
<b>Brackets:</b>				
Bracket Type:				
Bracket Dimensions:				
Remedial Action needed (if any):				
<b>Sign Off and Approval:</b>				
Signed and dated by Inspection Electrician:				
Print Name of Inspection Electrician:				
Checked, Signed and dated by Manager:				
Print Name of Manager:				
<i>Note : Please use additional Sheets where required and number them.</i>				
<i>Note: Attach Map showing location of poles and pillars.</i>				

## Appendix D

### Figures & Drawings

Figure 1: Lantern on 6m Column



#### Steel Tapered Column

6 metre 16 sided rolled steel, tapered, galvanized, and painted steel column ..

Root planted.

Base section : Ø140mm

Pole door aperture : 500 x100 mm

Figure 2: Typical 8m Octagonal Column

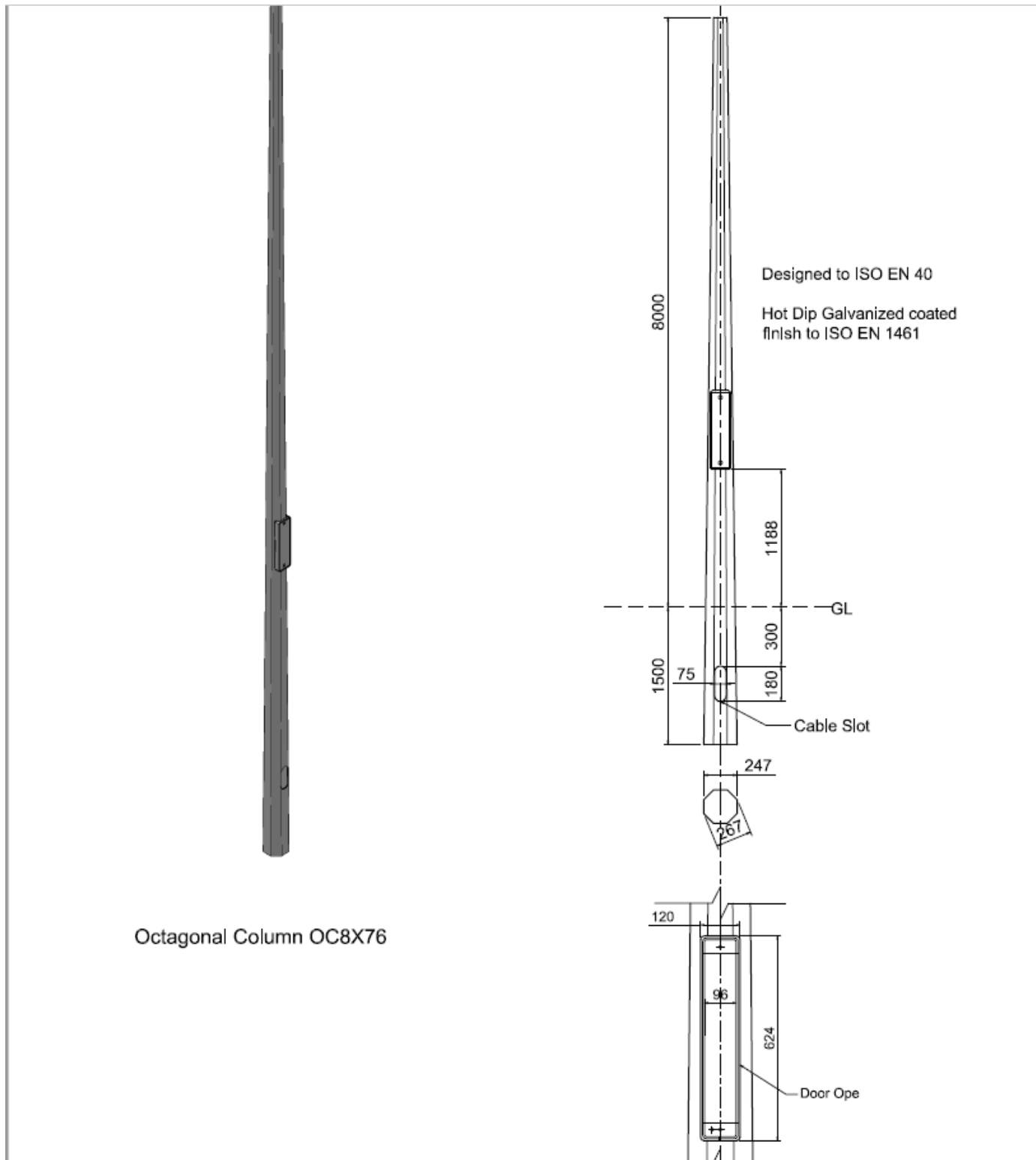



Figure 3: 32W LED lantern on 6m Column



Figure 4: ESB Minipillar & Preformed Vault with cover

Electrical Services Guidebook for Housing Schemes – Revision 4 – November 2012

Photo showing:

- correct use of PL tape
- correct use of ESBN tape
- approved prefabricated vault

NB Block built minipillar vault is not acceptable



Figure 5: Services Ducts relationship.

Electrical Services Guidebook for Housing Schemes – Revision 4 – November 2012

### Position and Spacing of ESB Networks Ducting in relation to other Utility Ducts and Pipes in Housing Schemes/Developments

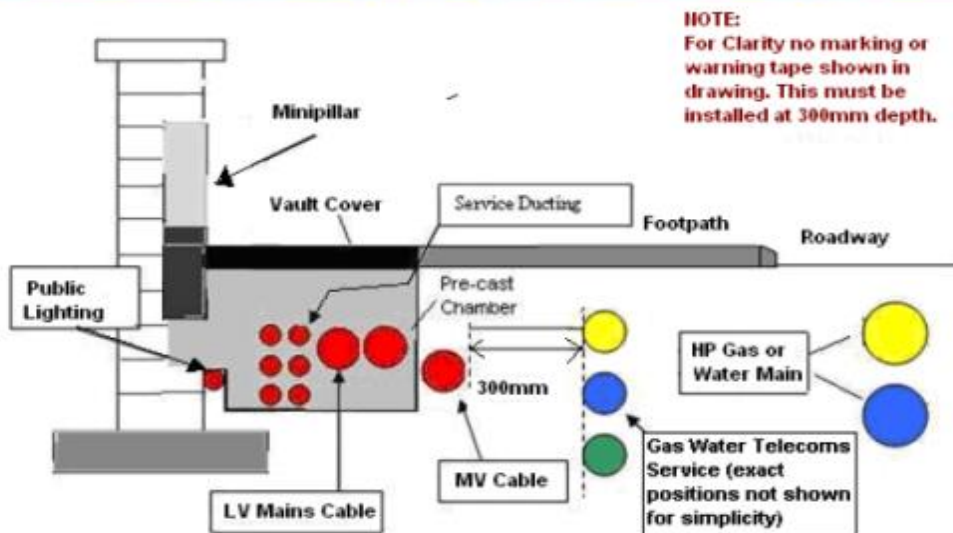

Normal standard clearance = 300mm.

Clearance from High Pressure pipes = 600mm

Figure 6: ESB Pillar (with 25m of free issue 25mm.sq. bare Cu. earthwire,) vault ,and cover + Lighting Pillar

Electrical Services Guidebook for Housing Schemes – Revision 4 – November 2012

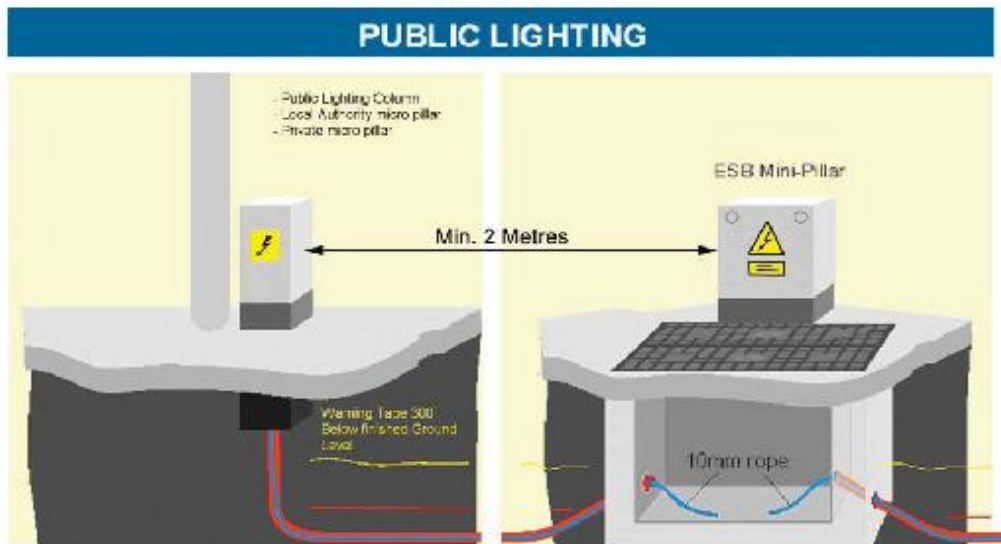

Page 58 of 61

Figure 7: ESB Minipillar, vault, & cover frame

## PRE-FABRICATED MINIPILLAR VAULT

Prefabricated minipillar vault showing minipillar in place complete with cover frame.

Note knockouts are provided for entry of mains and service-cable ducts.

Should be installed according to instructions provided with the unit.



Free issue ESB minipillar and 25m of 25 sq mm copper. Vault frame, ducting and cover to be provided by Contractor

Figure 8: Unmetered/Metered Lighting Pillar with ESB equipment

**Public Lighting** midi-pillar  
 Suitable for single/3 phased and surge protection

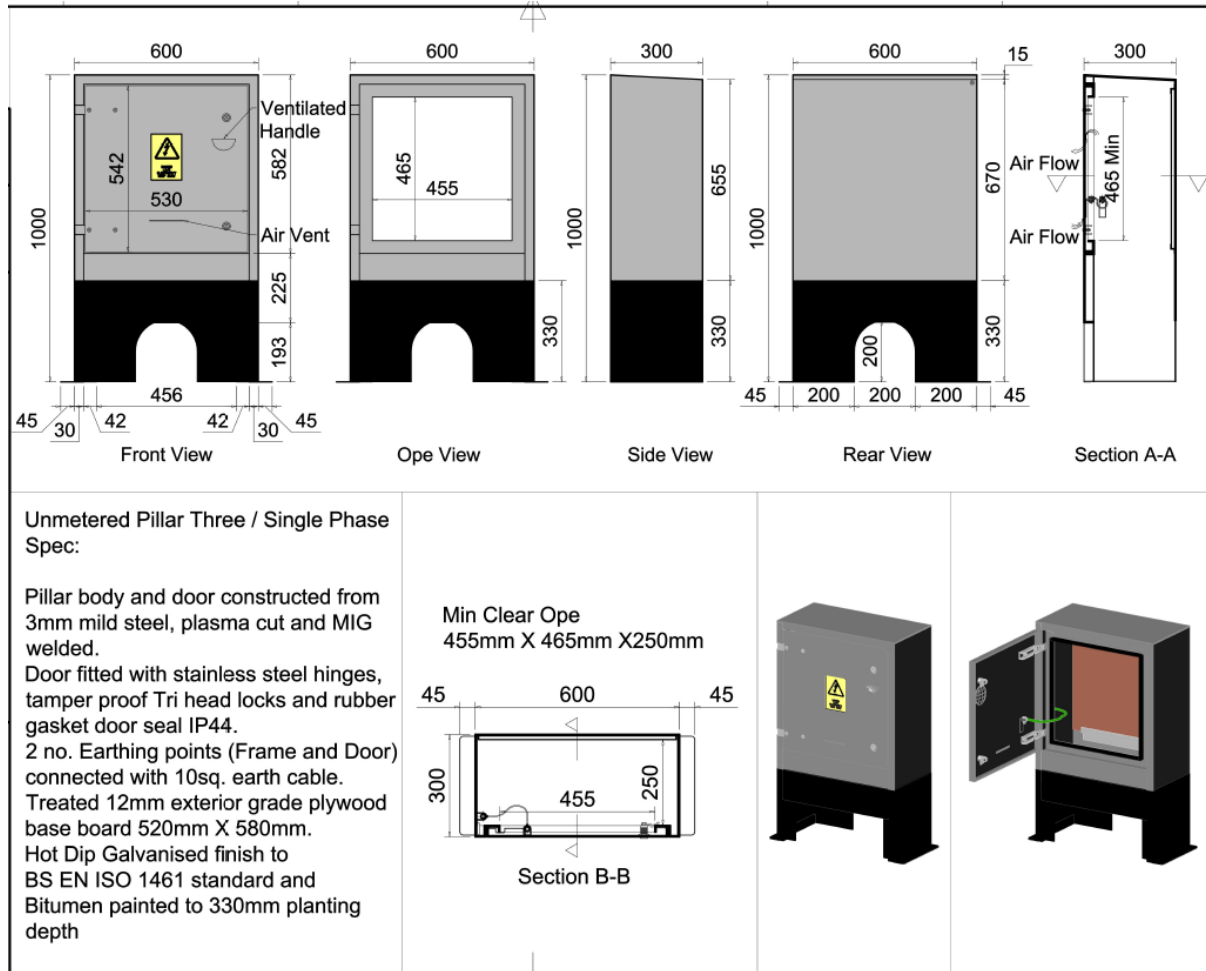

A pillar box for Public Lighting should contain the following;

1. A 0.6 modular box
2. A main switch fuse or mbc 25-amp max
3. A surge protection unit
4. An mcb to supply one circuit only ( you cannot double up on one mcb meaning you cannot have two circuits coming off one mcb)
5. A pillar must be earthed at all points (door, pillar ,main earth and circuits all bonded )

9b: Older type micro-pillar, (no longer recommended for new lighting schemes )

**Public Lighting**  
**Single Phase Pillar (unmetered)**



Dimensions  
150mm deep x 250mm wide x 600mm  
high/above ground  
(Root depth: 320mm)

Minimum ope size  
220mm wide x 510mm high

Space requirements  
ESB: 125mm wide **LHS**  
Customer: 125mm wide **RHS**

Equipment shown  
ESB Single Phase Cut Out  
ESB Single Phase Isolator

- Warning label "Live electricity" required on doors.
- 8mm triangular locks required on doors.
- Fire retardant back plate.
- Enclosure should have no sharp edges.

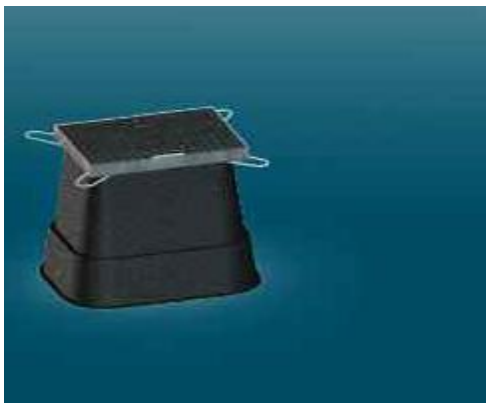

250mm wide vault and cover located in front of minipillar



**Public Lighting**  
**Combined Networks/Customer Pillar**  
**Three Phase/Single phase (Metered)**



Dimensions

600mm wide x 1500mm high x 220mm deep.

Minimum ope size

518mm wide x 570mm high x 220 deep for Networks equipment.

600mm Minimum to bottom of meter.

NOTES:

1. Hinged Door for access to Networks equipment.
2. Steel trunking (sealable) for Networks cable

Equipment shown

- ESB Three Phase Cut Out
- ESB Three Phase Meter
- ESB Three Phase Isolator



- Warning label "Live electricity" required on doors.
- 8mm triangular locks required on doors.
- Fire retardant back plate.
- Enclosure should have no sharp edges.

600mm wide vault and cover  
 Located in front of minipillar



1.2m 16 sq mm galvanised steel earth rod and chamber for neutralising connection at minipillar

Figure 10: Pole Mounted Interface box with ESB equipment

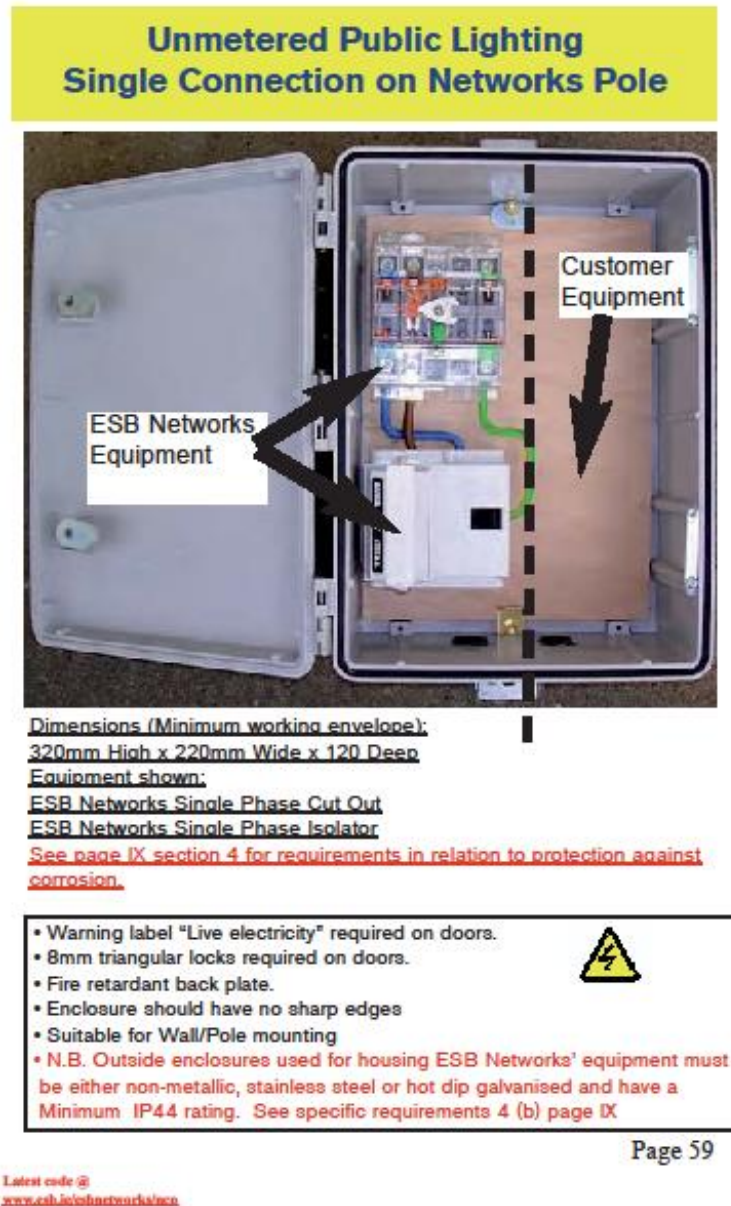

Figure 11: Lighting Column Door.



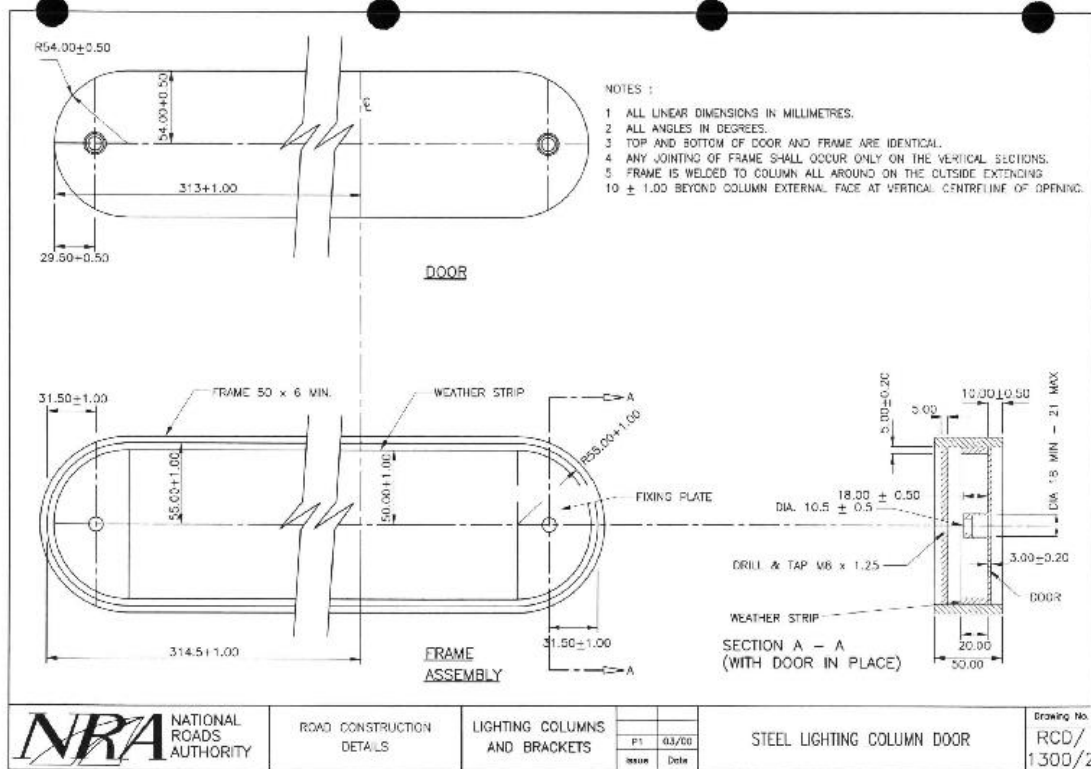

Figure 12: Painting Detail for Galvanised Column in Marine Environment

Table 3

Painting galvanized steel for maximum long term protective life  
 Exposure condition 3  
 Heavy industrial, marine exposure and possibility of abrasion

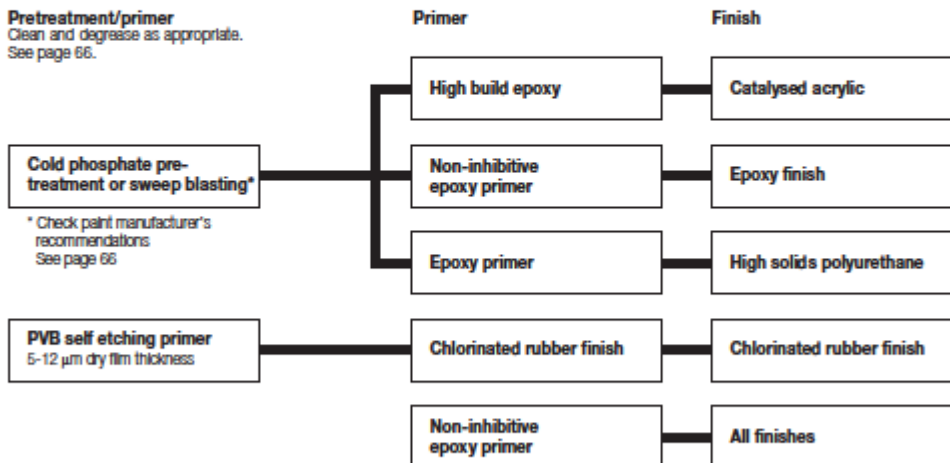
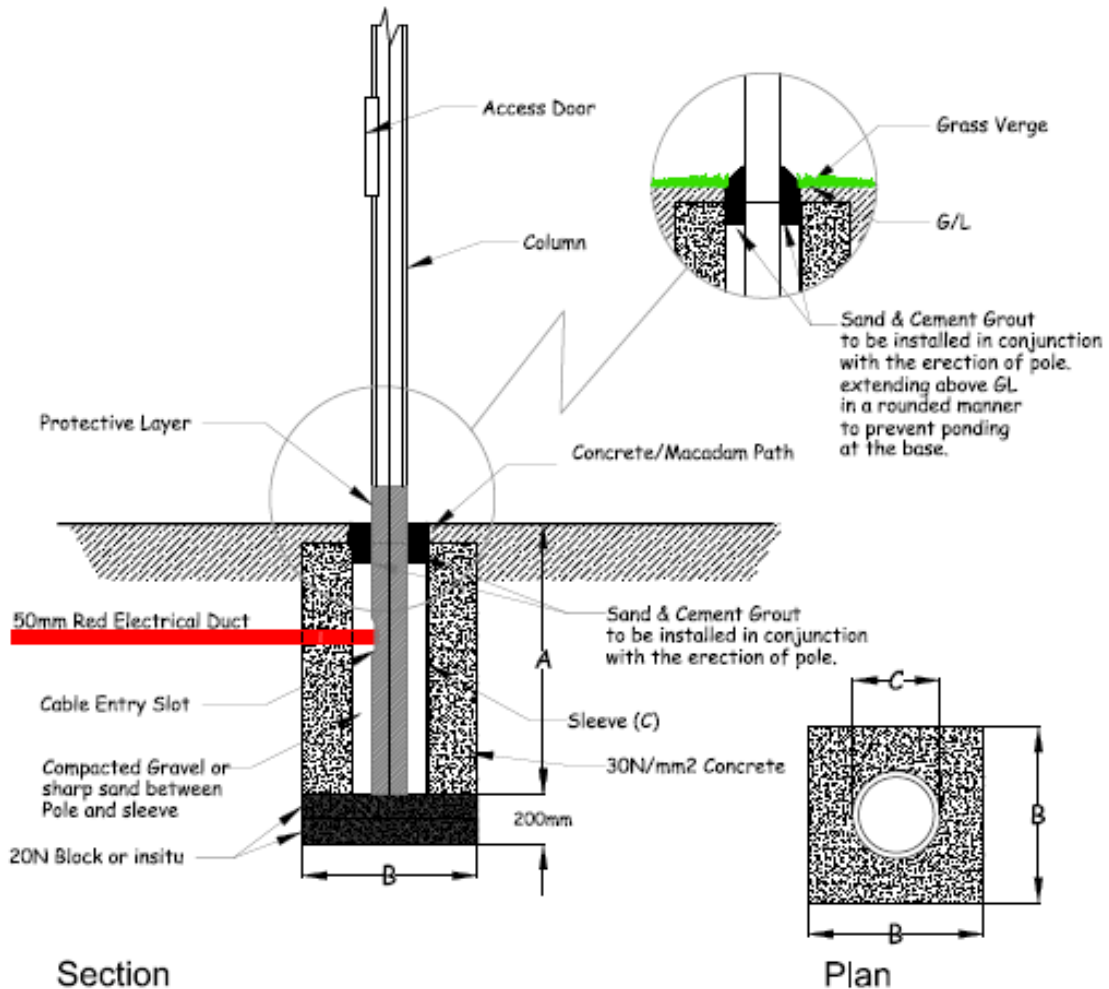

Figure 113a: Column Base Details – Rooted column

Notes : Typical foundation details are provided for guidance only and the soil conditions should be checked by the a qualified engineer on site.  
 Actual Foundation size and depth should be designed with reference to prevailing ground and wind conditions.  
 Foundations should be constructed using 30N/mm<sup>2</sup> Concrete.  
 A minimum curing period of 14 days should be allowed.  
 Special precautions must be taken where poor ground conditions exist.  
 Cable entry /exit ducts in the centre of the foundation.

Column Height Dim	TYPICAL ROOTED COLUMN BASE SIZES				
	6m	8m	10m	12m	14m
A	1000	1500	1800	1800	2000
B	700	800	800	1000	1300
C	300	375	400	400	



Not To Scale

Typical Rooted Column Foundation Details.



Cork County Council,  
 Management & Development Roads  
 (Public Lighting Section)  
 June 2020

Figure 13b: Column Base Details – flanged column

Notes : Typical foundation details are provided for guidance only and the soil conditions should be checked by the a qualified engineer on site.  
 Actual Foundation size and depth should be determined with reference to prevailing ground and wind conditions.  
 Foundations should be constructed using 30N20 Concrete.  
 A minimum curing period of 14 days should be allowed.  
 Special precautions must be taken where aggressive ground conditions exist.  
 Cable entry ducts which should exit in the centre of the foundation.  
 Foundation bolts assembly must be fixed in the correct position.  
 The specified projection of bolts above the foundation must be observed.

TYPICAL FLANGED COLUMN BASE SIZES					
Column Height	6m	8m	10m	12m	14m
Dim A	625	825	1100	1150	1250
Dim B	950	1350	1900	2000	2100

Standard Bolt Sizes	Projection Above Ground
M16 x 450mm J-Bolts	80mm
M24 x 550mm J-Bolts	90mm
M27 x 850mm Stud	170mm

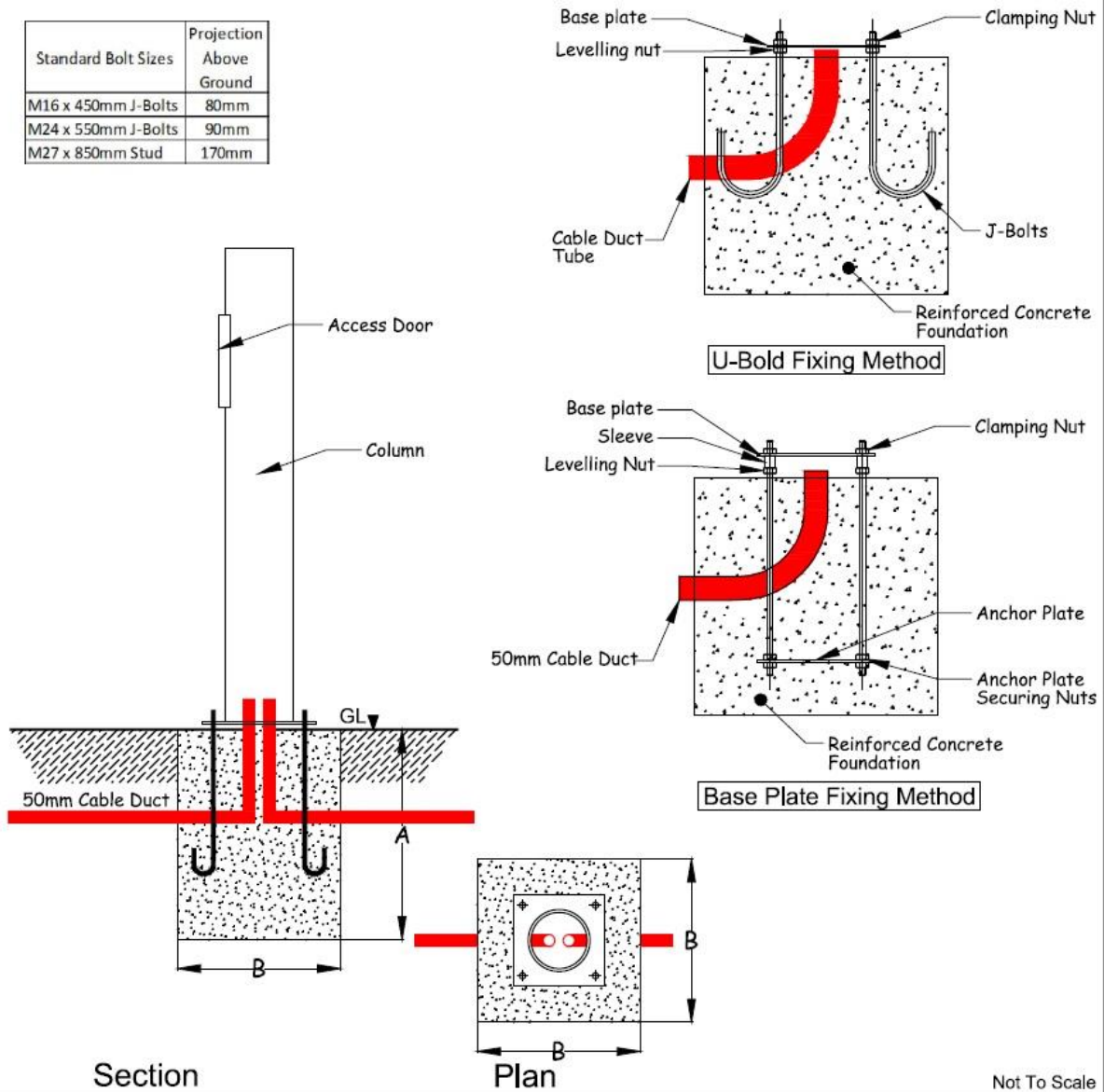

Not To Scale

Typical Flanged Column Foundation Details.



Cork County Council,  
 Management & Development Roads  
 (Public Lighting Section)

Figure 14: Zebra Crossing Detail

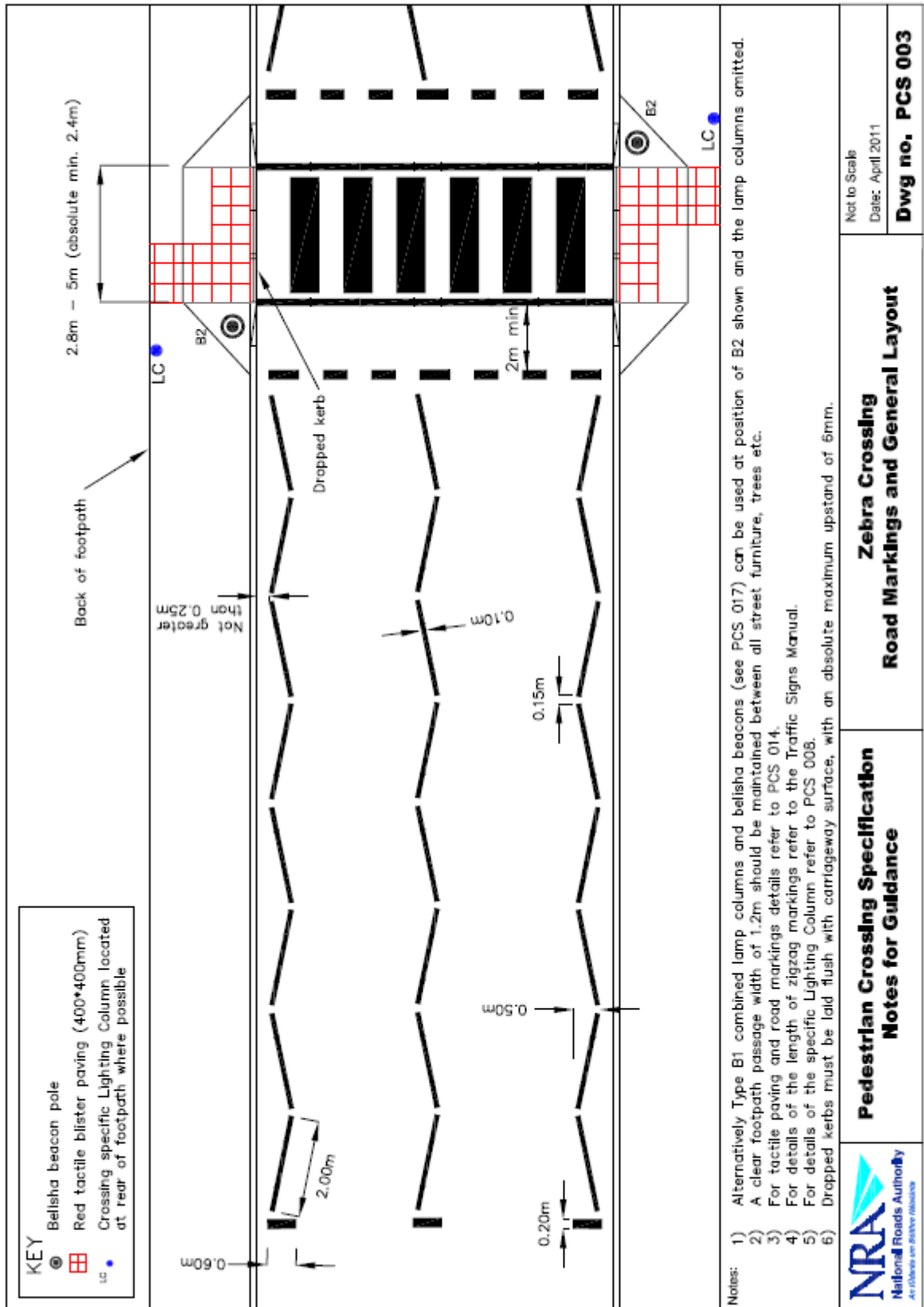

Figure 15: Zebra Crossing with Island General Layout

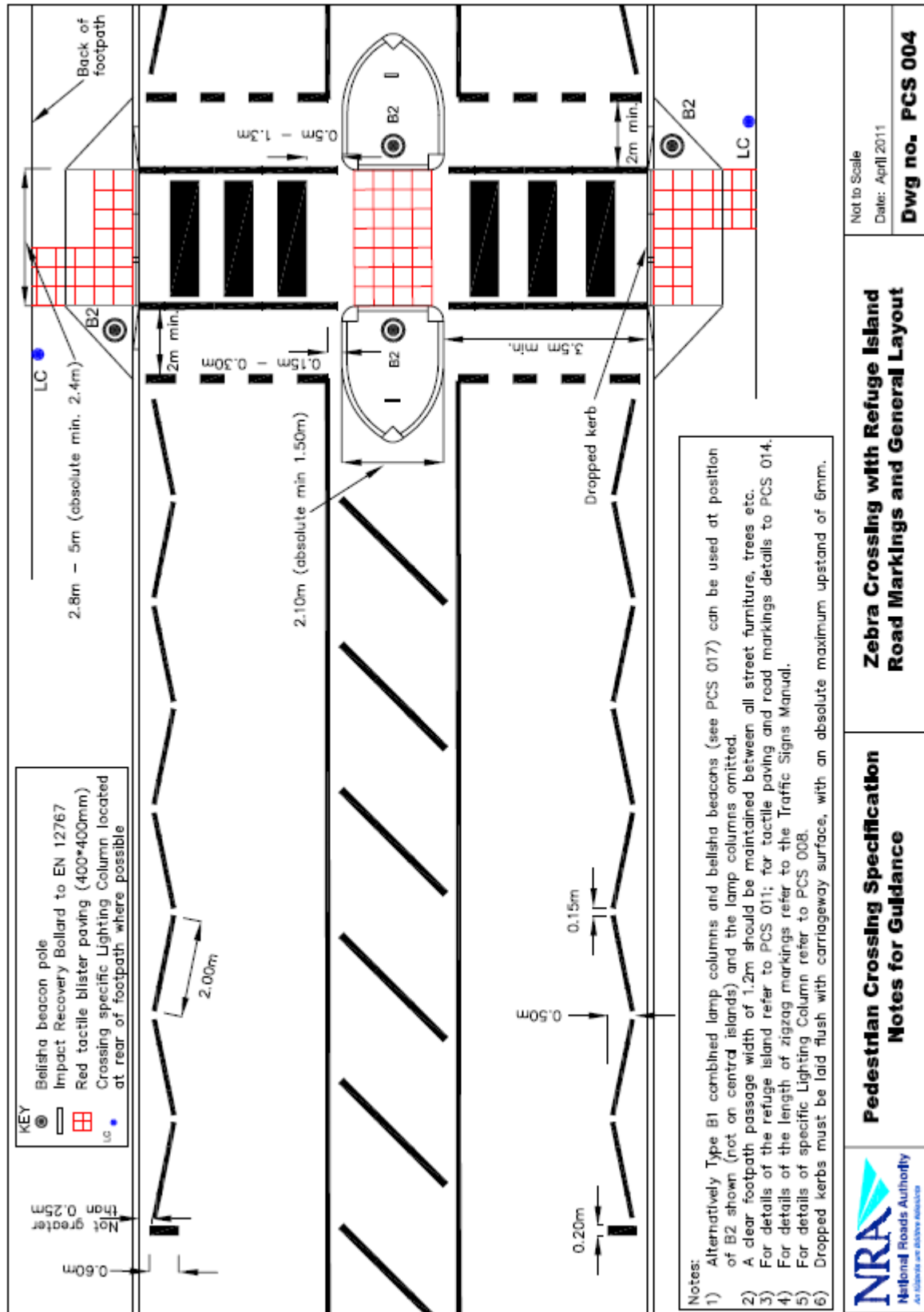

Figure 16: Supplementary Lighting Detail for all types of crossing

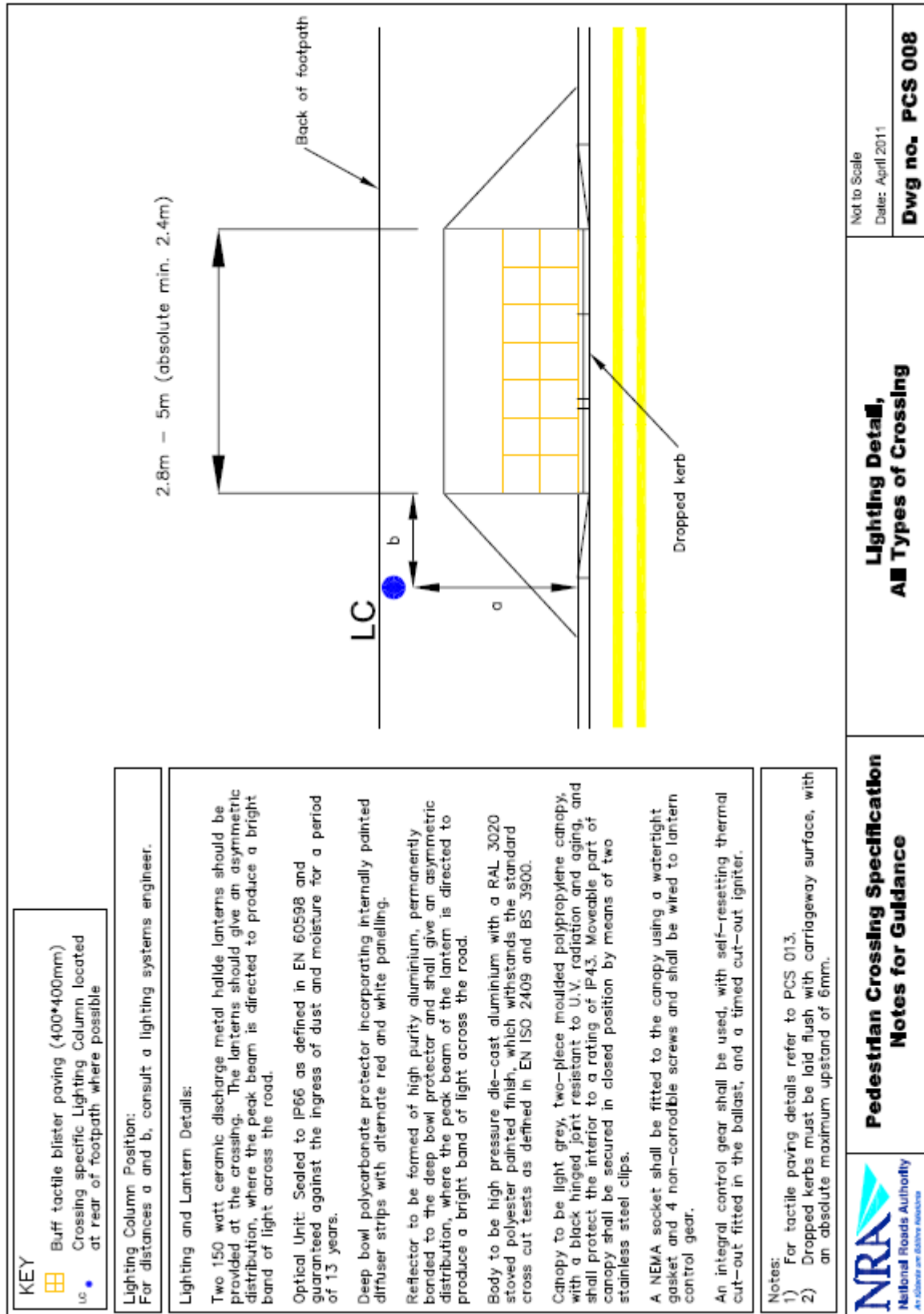
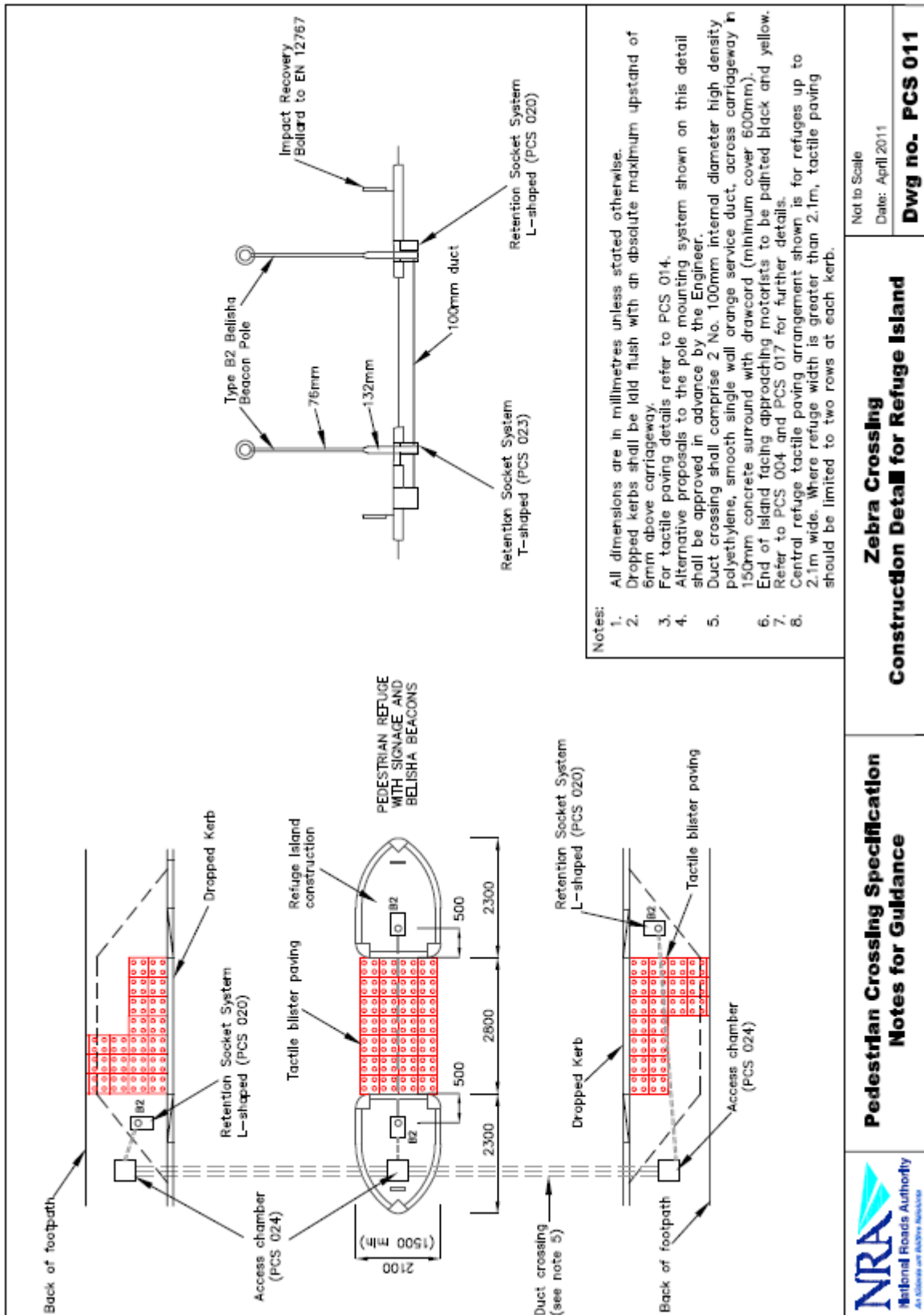

Figure 17: Construction Detail for Zebra Crossing Refuge Island



**Pedestrian Crossing Specification  
Notes for Guidance**

**Zebra Crossing  
Construction Detail for Refuge Island**

Not to Scale  
Date: April 2011  
**Dwg no. PCS 011**

Figure 18: Belisha Beacon Pole Detail

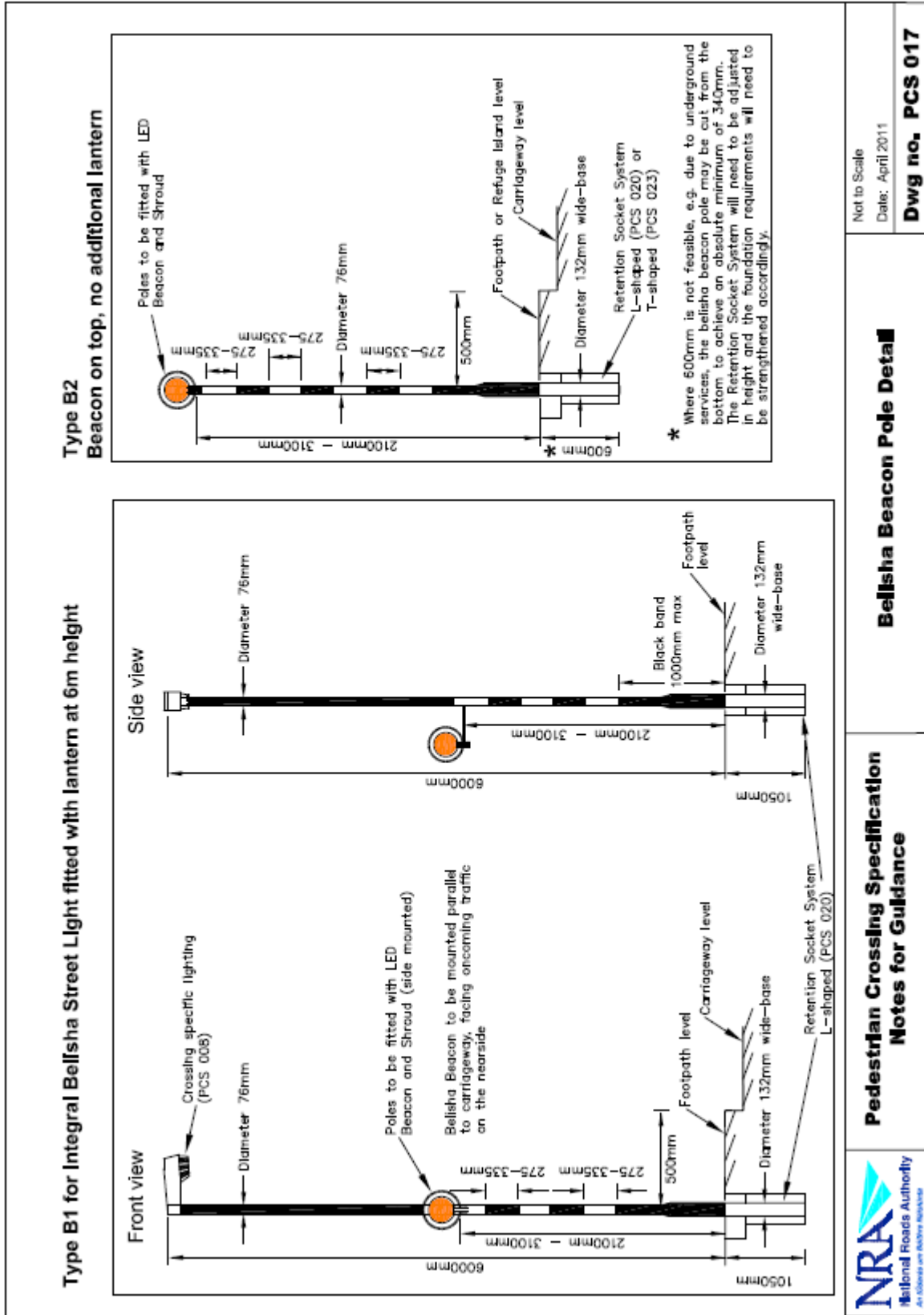
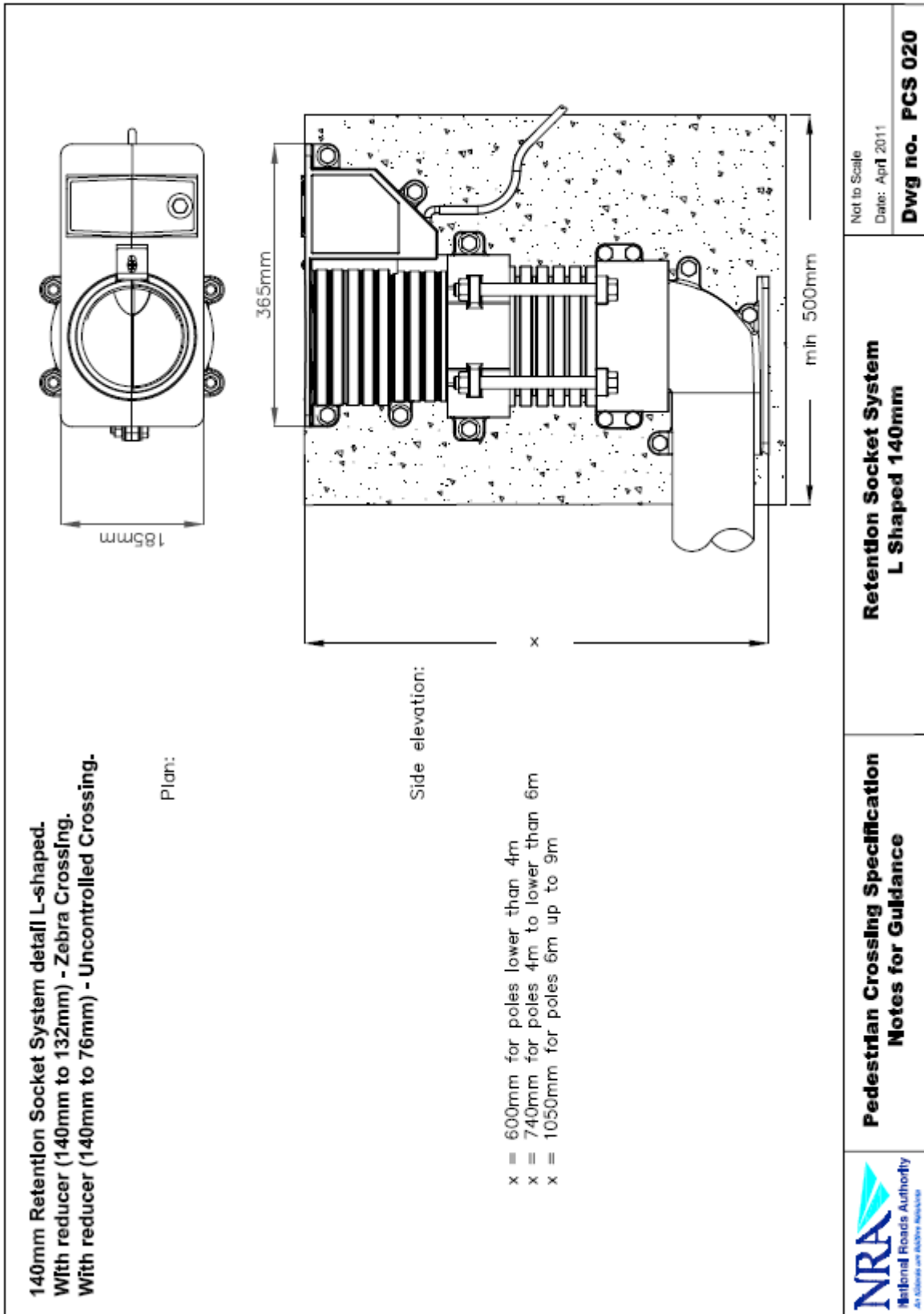





Figure 19: Retention Socket System for Zebra Crossing



# Appendix E – NC4 Unmetered Supply Application Form

Figure 1: NC4 Unmetered Supply Application Form



esbnetworks.ie

## FORM NC4

### APPLICATION FOR UNMETERED CONNECTIONS

(INC. PUBLIC LIGHTING)

ESB Networks DAC requires the information requested on this application form to enable us to set up and manage your electricity supply connection. As the Distribution System Operator, this information is also required to enable ESB Networks DAC to manage the electricity network. The data controller is ESB Networks DAC. Please refer to our privacy policy at <https://esbnetworks.ie/privacy>

**Please fill in ALL sections in BLOCK CAPITALS**  
**Do not leave any section blank; N/A to be used if it doesn't apply.**

FOR OFFICIAL USE ONLY  
 NOTIFICATION NO: \_\_\_\_\_

**1. APPLICANTS FULL NAME AND FULL SITE ADDRESS WHERE THE CONNECTION POINTS ARE TO BE PROVIDED.**  
**(If a company /partnership/Local Authority give full COMPANY OR TRADING NAME). Please note if applying on behalf of a client (in the case of consultants) a letter of authorisation is required**

Title: Mr  Mrs  Ms  Company / Other \_\_\_\_\_

\_\_\_\_\_

\_\_\_\_\_

\_\_\_\_\_

\_\_\_\_\_

\_\_\_\_\_

Mobile number: \_\_\_\_\_ Landline: \_\_\_\_\_

Email: \_\_\_\_\_

**2. BILLING ADDRESS OF REGISTERED COMPANY**

\_\_\_\_\_

\_\_\_\_\_

\_\_\_\_\_

\_\_\_\_\_

\_\_\_\_\_

**3. CONTACT NAME & ADDRESS FOR CORRESPONDENCE (if different from section 1.)**

Title: Mr  Mrs  Ms  Company / Other \_\_\_\_\_

\_\_\_\_\_

\_\_\_\_\_

\_\_\_\_\_

\_\_\_\_\_

Mobile number: \_\_\_\_\_ Landline: \_\_\_\_\_

Email: \_\_\_\_\_

**4. EXISTING CUSTOMERS ONLY**

If applicable, please provide the GMPRN you wish to add the connection points to. \_\_\_\_\_

**5. SITE PLAN & LOCATION OF CONNECTION POINTS.**

Please attach an Ordinance Survey map(scale 1:2500-1:10560) showing the location of your site and a site plan(scale1:100-1:500) showing the location of the connection points.  
**Please note that we will not be able to process your application without these maps.**

**6. ELECTRICITY SUPPLIER**

Following the receipt and payment of quotation, you should also register with an Electricity Supplier.  
**A list of electricity suppliers is available on CRU.ie**

7. INVENTORY LOADS AT UNMETERED CONNECTION POINTS						
Connection Point No. (i.e. 1st, 2nd)	Connection Point Address (Exact location required. e.g. Outside House Number#)	Unmetered Type*	Equipment Type**	Actual Wattage	Burning Hour Calendar***	Number of Each Type of Equipment
	Public Lighting, Traffic Lights, Pedestrian Lights, Traffic Signs, School Warning Lights, Bollards, Beacons, Advertising Signs, Shrine Lighting, Bus Shelters, Kiosks, Parking meters, Electric fences, Cable TV, Boosters, CCTV, etc.					
	**Equipment Types e.g. Lighting:					
	SOX (35/55/90/135 watt); SXHF(55 watt); SON (70/100/150/250/400/600 watt); LED etc..					
	***BHC:					
	Burning Hour Calendar : + Time period during which lighting will be switched on e.g. DM=Dusk to Midnight, DD=Dusk to Dawn, 24 Hours.					

**SIGNATURE OF OWNER/AUTHORIZED SIGNATORY**

Signed: \_\_\_\_\_ Full Name (BLOCK CAPITALS): \_\_\_\_\_

Position Held: \_\_\_\_\_ Date: \_\_\_\_\_

You accept ESB Networks DAC general conditions relating to connection and all amendments, which the Commission for Energy Regulation may approve from time to time. You agree to let ESB Networks DAC connect the network to your equipment. You acknowledge that we are entitled to connect other customers to the network. We may need evidence that you have the authority to sign this form.

**DATA PROTECTION**

Personal data provided by you in this application form will be disclosed to other parties in the following circumstances:

- ESB Networks DAC will use the information supplied on this form for the purposes of managing your electricity supply connection and the electricity network and performing its functions as Distribution System Operator. In performing these functions, ESB Networks DAC may utilise the services of contracted third party data processors. ESB Networks DAC may disclose your data to these third party data processors, which are only permitted to use your data as instructed by ESB Networks DAC. They are also required to keep your data safe and secure. By signing this application you consent to this use of your personal data.
- ESB Networks DAC may make available the existence, location and/or technical aspects of your connection to licensed Electricity Supply Companies and other parties involved in your electricity supply. In the case of new connections, ESB Networks DAC will make available your telephone contact number to licensed Electricity Supply Companies in order to facilitate engagement of the connection. By signing this application you consent to this use of your personal data.
- If you contact us requesting energisation prior to securing a supplier, you authorise ESB Networks DAC to disclose the details on this form to the Public Electricity Supplier who will then default as your supplier. By signing this application you consent to this use of your personal data.
- Please note that ESB Networks DAC may be required by law, or our license obligations, to provide data that ESB Networks DAC holds about you, your electricity supply or connection, to government agencies or departments, the Commission for Regulation of Utilities or other third parties.
- Contact details may also be provided to a professional third party market research company for the purposes of researching your satisfaction with the services provided by ESB Networks DAC. This information may also be used to enhance our services as the Distribution System Operator.

**Note: We cannot accept responsibility for delays or mistakes if you have not filled out this application correctly. If the form is not complete, we will return it to you.**

**NB PLEASE REMEMBER TO:**

- Sign and Date the Application Form
- Include your O.S. map and site plan for connection.
- Fill in Load details in Section 7
- Fill in all contact details (a valid telephone number is essential)

PLEASE RETURN FORM TO:  
umrdbase@esb.ie  
or by Post to UMR,  
ESB NETWORKS DAC,  
ABBYLEIX ROAD,  
PORTLAOISE CO. LAOIS.  
R32 HR02

**PLEASE REMEMBER!**  
DON'T BUILD UNDER OR NEAR ELECTRICITY WIRES  
**STAY SAFE STAY CLEAR**  
**OF ELECTRICITY WIRES**  
ESB NETWORKS DAC



**ESB Networks DAC**

Directors: Jerry O'Sullivan (Chairman),  
Paddy Hayes, Paul Mulvaney, Caroline Spillane,  
Ian Talbot.  
Registered office: Clanwilliam House, Clanwilliam  
Court, Dublin 2, D02 CV61, Ireland  
Registered in Ireland No. 465172

## **Appendix F – Extract from TII Publications DN-LHT-03038 Aug 2018 relating to the illumination of Traffic Calming gateways and Pedestrian Crossings.**

*(Extract from TII Publications DN-LHT-03038 Design of Road Lighting for the National Road Network August 2018, Page 32 )*

### **5.7 Lighting for Traffic Calming Features**

Gateways, as described in DN-GEO-03084 Transition Zone Treatment of Towns and Villages on National Roads, that are positioned between the rural fringe and the transition zones to towns and villages to inform drivers that they are arriving in an urban area with an associated reduction in speed are to be illuminated.

The lighting shall extend for two columns (approx. 60m) on the approach to the gateway leading into the lit urban area and shall be lit to the same BS 5489-1 lighting class that exists on the section of road immediately beyond the gateway.

In the immediate locality of the traffic calming gateway, which is generally the demarcation between a rural and urban environment, a higher level of illuminance is required. For further guidance on the layout of traffic calming gateways refer to DN-GEO-03084.

Lighting sources on the approach to the gateway and at the gateway location as described earlier in this Section shall have a minimum colour rendering index of 65.

The gateway locations shall be considered as Conflict Areas and follow the principles of BS 5489-1 in applying a step up in lighting class compared to the lighting class that has been adopted for the road lighting on the section of road that passes through the gateway. Illuminance based criteria (CE/C lighting class) shall be applied to the lighting of gateways. The minimum lighting class shall be C/CE4. The step up in lighting class can be achieved by either the reuse of the existing road lighting system, the retrofit of lanterns in the immediate vicinity of the gateway or the installation of supplementary lighting directly adjacent to the gateway.

For the reuse of the existing road lighting, the designer shall undertake BS 5489-1 calculations to satisfy that the appropriate illuminance and uniformity values of the step up in lighting class can be achieved in the immediate locality of the traffic calming gateway.

Lighting columns shall be kept clear and to the rear of footpaths and cycleways and shall not be located on central gateway islands.

For areas subject to a speed limit greater than 85km/h or at or in close proximity to a gateway, lighting shall conform to the requirements of Section 3.8 in relation to the use of passively safe columns.

Gateways will generally not be used as pedestrian crossings however, where gateways are used for the purpose of a pedestrian crossing, then the requirements of Section 5.8 shall be followed.

### **5.8 Lighting of Pedestrian Crossings**

The provision of lighting at pedestrian crossings shall be considered in conjunction with the guidance contained in DN-GEO-03084 Transition Zone Treatment of Towns and Villages on National Roads.

#### **5.8.1 Zebra Controlled Crossings**

All zebra controlled crossing locations are to be provided with additional local lighting and

illuminated to provide both vertical and horizontal illuminance as detailed in Section 5.8.3. The additional local lighting arrangement on a belisha beacon pole shall be as shown in DN-GEO-03084.

## **8.2 Controlled Signalised and Uncontrolled Crossings**

Street lighting normally provides an adequate level of illumination on to the road surface so that objects can be seen in silhouette (negative contrast).

Controlled signalised crossings, with a pushbutton facility for pedestrians shall normally have an adequate level of illumination where the traffic route lighting has been designed to BS 5489-1 and will not generally require any additional localised lighting at the crossing point.

**For uncontrolled crossings** with a lit area designed to BS 5489-1 lighting class ME3/M3 or higher, and with the placement of street lighting in proximity to the crossings that provides good negative contrast, additional localised lighting at the crossing may not be required.

Consideration shall be given to the use of additional localised lighting where the existing road lighting arrangements cannot provide illumination that ensures good negative contrast, and where positive illumination would enhance the ability of motorists to observe pedestrians approaching and crossing the road during the hours of darkness.

Situations that may require additional localised lighting include where crossings are located on a bend or on the brow of a hill and in situations where the crossing may be inconspicuous or obscured. Additional local lighting shall also be considered for uncontrolled crossings that are lit to a BS 5489-1 lighting class lower than ME3/M3. Section 5.8.3 details the requirements for additional local lighting. Further guidance can be found in the ILP Technical Report No. 12. Controlled signalised and uncontrolled crossings within the confines of a Conflict Area that have a step up in lighting class applied may have an adequate level of illumination that will negate the need for additional localised lighting at the crossing point.

In some instances, a traffic route may consist of several uncontrolled crossings in close proximity to each other. Providing dedicated supplementary localised lighting at each crossing location to provide positive illumination needs to be balanced in terms of its day time appearance and unnecessary street clutter. The lighting designer shall take cognisance of DMURS<sup>32</sup> when considering lighting within urban areas and the built environment.

### **5.8.3 Additional Localised Lighting Illumination Requirements**

Where additional localised lighting is being provided it shall be illuminated to the following parameters:

- a) The minimum average horizontal illuminance on the crossing carpet to be 3.5x greater than the designed average horizontal illumination of the road with an overall uniformity of 0.6; and
- b) The minimum vertical illuminance shall be as follows:
  - i) Centre of crossing to be 2x nominal average horizontal road illuminance;
  - ii) Kerb edge to be 2x nominal average horizontal road illuminance; and
  - iii) Rear of waiting area to be 1.5x nominal average horizontal road illuminance.

Lighting sources used for additional localised lighting at crossings shall have a minimum colour rendering index of 65.

The illumination areas and grids for the additional localised lighting are detailed in the ILP Technical Report No. 12.

## Appendix G – Available dimming profiles

The UMR, unmetered registry, changed the references on dimming profiles/burn profiles, to those outlined in the table below.

When applying for a new connection it is important to include the actual burn hour calendar reference and not just to state D2D on the application form.

Standard Profile	Burning Hour Calendar	Description
10	24H	Public Lighting Load Profile 10 - 24 Hour
11	D2D	Public Lighting Load Profile 11 - Dusk/Dawn
12	D2M	Public Lighting Load Profile 12 - Dusk/Midnight
13	U13	Public Lighting Load Profile 13 - Dusk/Dawn with Extra Trimming
14	U14	Public Lighting Load Profile 14
	U14A	Public Lighting Load Profile 14 - Hours not dimmed
	U14B	Public Lighting Load Profile 14 - Hours dimmed to 75% (between midnight and 06.00 hrs)
15	U15	Public Lighting Load Profile 15
	U15A	Public Lighting Load Profile 15 - Hours not dimmed
	U15B	Public Lighting Load Profile 15 - Hours dimmed to 67% (between midnight and 06.00 hrs)
16	U16	Public Lighting Load Profile 16
	U16A	Public Lighting Load Profile 16 - Hours not dimmed
	U16B	Public Lighting Load Profile 16 - Hours dimmed to 50% (between midnight and 06.00 hrs)
17	U17	Public Lighting Load Profile 17
	U17A	Public Lighting Load Profile 17 - Hours not dimmed
	U17B	Public Lighting Load Profile 17 - Hours dimmed to 75% (from 21:00 through to 07:00 next day)
18	U18	Public Lighting Load Profile 18
	U18A	Public Lighting Load Profile 18 - Hours not dimmed
	U18B	Public Lighting Load Profile 18 - Hours dimmed to 67% (from 21:00 through to 07:00 next day)
19	U19	Public Lighting Load Profile 19
	U19A	Public Lighting Load Profile 19 - Hours not dimmed
	U19B	Public Lighting Load Profile 19 - Hours dimmed to 50% (from 21:00 through to 07:00 next day)
20	U20	Public Lighting Load Profile 20
	U20A	Public Lighting Load Profile 20 - Hours not dimmed
	U20B	Public Lighting Load Profile 20 - Hours dimmed to 75% (from 20:00 to 22:00)
	U20C	Public Lighting Load Profile 20 - Hours dimmed to 50% (from 22:00 until 07:00 next day)
21	U21	Public Lighting Load Profile 21
	U21A	Public Lighting Load Profile 21 - Hours not dimmed
	U21B	Public Lighting Load Profile 21 - Hours dimmed to 67% (from 20:00 to 22:00)
	U21C	Public Lighting Load Profile 21 - Hours dimmed to 50% (from 22:00 until 07:00 next day)
22	U22	Public Lighting Load Profile 22
	U22A	Public Lighting Load Profile 22 - Hours not dimmed
	U22B	Public Lighting Load Profile 22 - Hours dimmed to 64% (from 20:00 to 22:00)
	U22C	Public Lighting Load Profile 22 - Hours dimmed to 47% (from 22:00 until 07:00 next day)
23	U23	Public Lighting Load Profile 23
	U23A	Public Lighting Load Profile 23 - Hours not dimmed
	U23B	Public Lighting Load Profile 23 - Hours dimmed to 64% (from 20:00 to 22:00)
	U23C	Public Lighting Load Profile 23 - Hours dimmed to 36% (from 22:00 until 07:00 next day)

### Trimming

Trimming is achieved through the use of 35/18 photocells associated with LED lights which reach their full potential immediately as against SON/SOX lights which took a while to reach working temperature. They used 70/35 photocells. Burn hours for the older lights was therefore recognised as 4150 hrs/year, whereas burn hours for LED lights on 35/18 is now deemed by ESNB to be 4095 hrs per year, thereby recognising the small % energy savings accruing from the use of 35/18 photocells with LED's. Note that the UMR insist that all lights within an MPRN must be LED to avail of energy savings to the lower 4095 hrs/year.

# One Step Dimming – Standard Period

Whilst the same time periods have been applied to the three profiles (2A, 2B, 2C) i.e. 12 midnight to 6am, the dimming percentage will very much depend on the change between lighting classes. The percentage reductions to be applied should always ensure that the lighting class parameters identified in BS EN 13201 can be achieved.

Lighting Classes refer to different lighting levels and other performance criteria. They are applied for different scenarios that cover the lighting for traffic routes, subsidiary roads (e.g. residential type) and city and town centres. These lighting classes are referred to as ME, M, S, P and CE and are defined in BS EN 13201-2.

## PROFILE U14

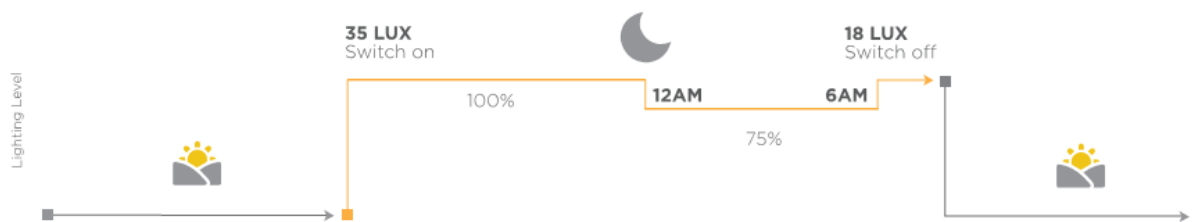

## PROFILE U15

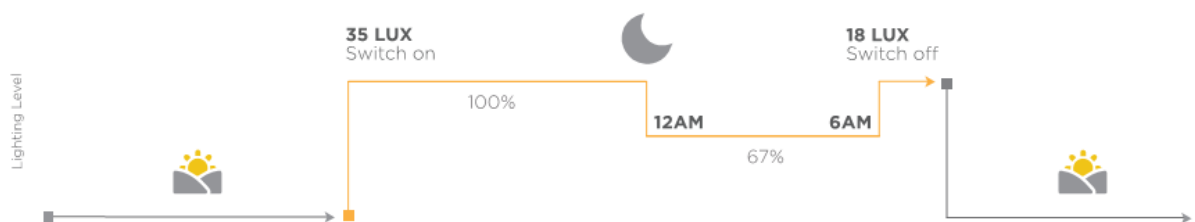

## PROFILE U16

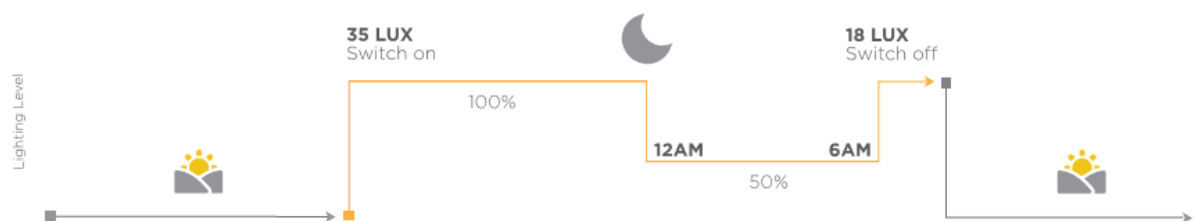

# One Step Dimming – Extended Period

While burn profiles U14, U15, and U16 are acknowledged as those that would be most prevalent across all local authorities, it is recognised that some local authorities will seek to introduce an extended period of dimming that could commence earlier in the evening and extend later in the morning as illustrated in the figure below.

## PROFILE U17

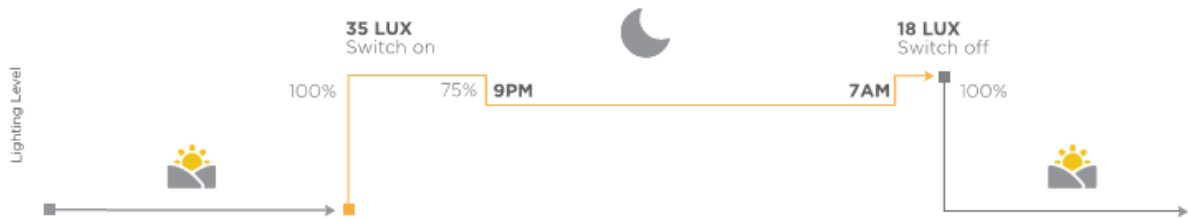

## PROFILE U18

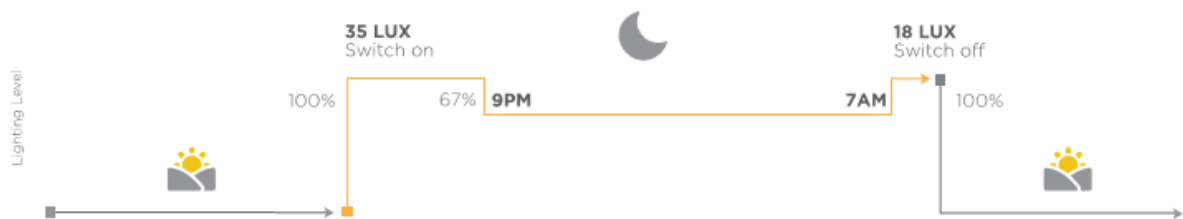

## PROFILE U19

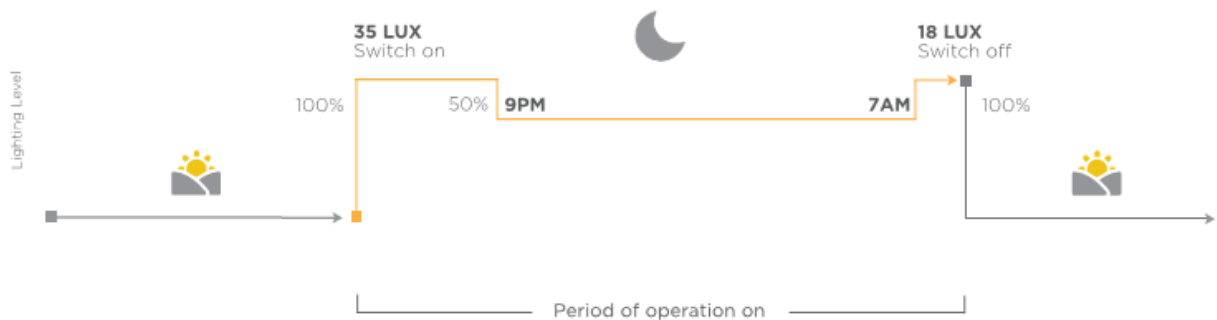



# Multi-Step (2-steps) Dimming

Multiple levels of dimming can also be applied during the hours of darkness to facilitate a stepped approach to dimming the lighting during the evening. The agreed profiles are shown in figure below:

below:

**PROFILE U20**

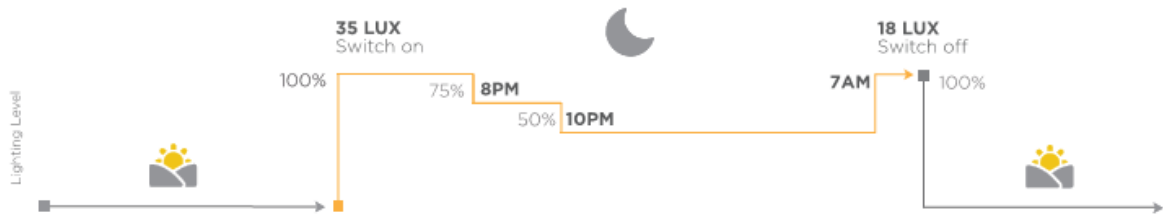

**PROFILE U21**

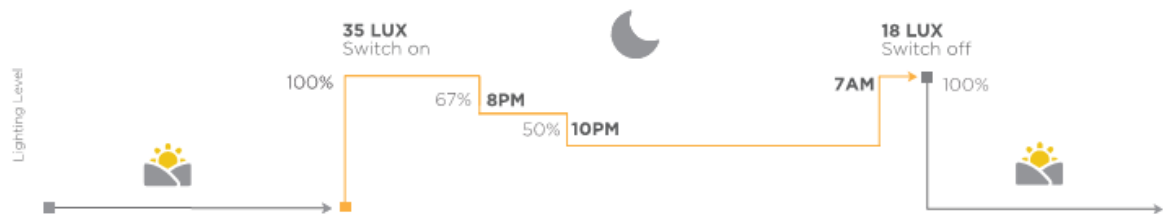

**PROFILE U22**

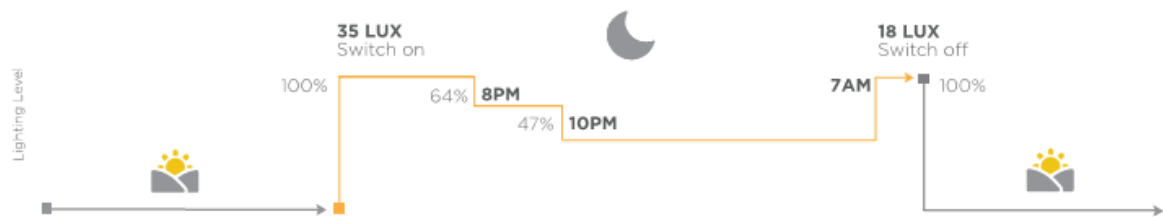

**PROFILE U23**

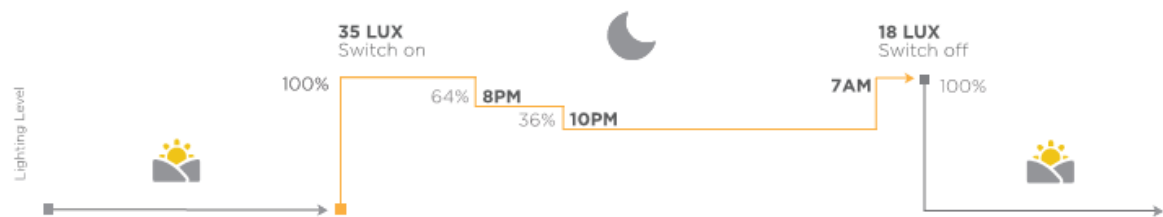

Period of operation on

# Appendix H – Planning Application documentation and Menu of Standard Planning conditions

**Figure 1: Typical Outdoor Lighting Report**

- Lantern A - 4.8Klm DW50 28W
- Lantern B - 13Klm DW50 74W
- Lantern C - 6.6Klm DX51 45W
- Lantern D - 6.2Klm DM50 42W
- Grid 1 and 2 meet P3 class

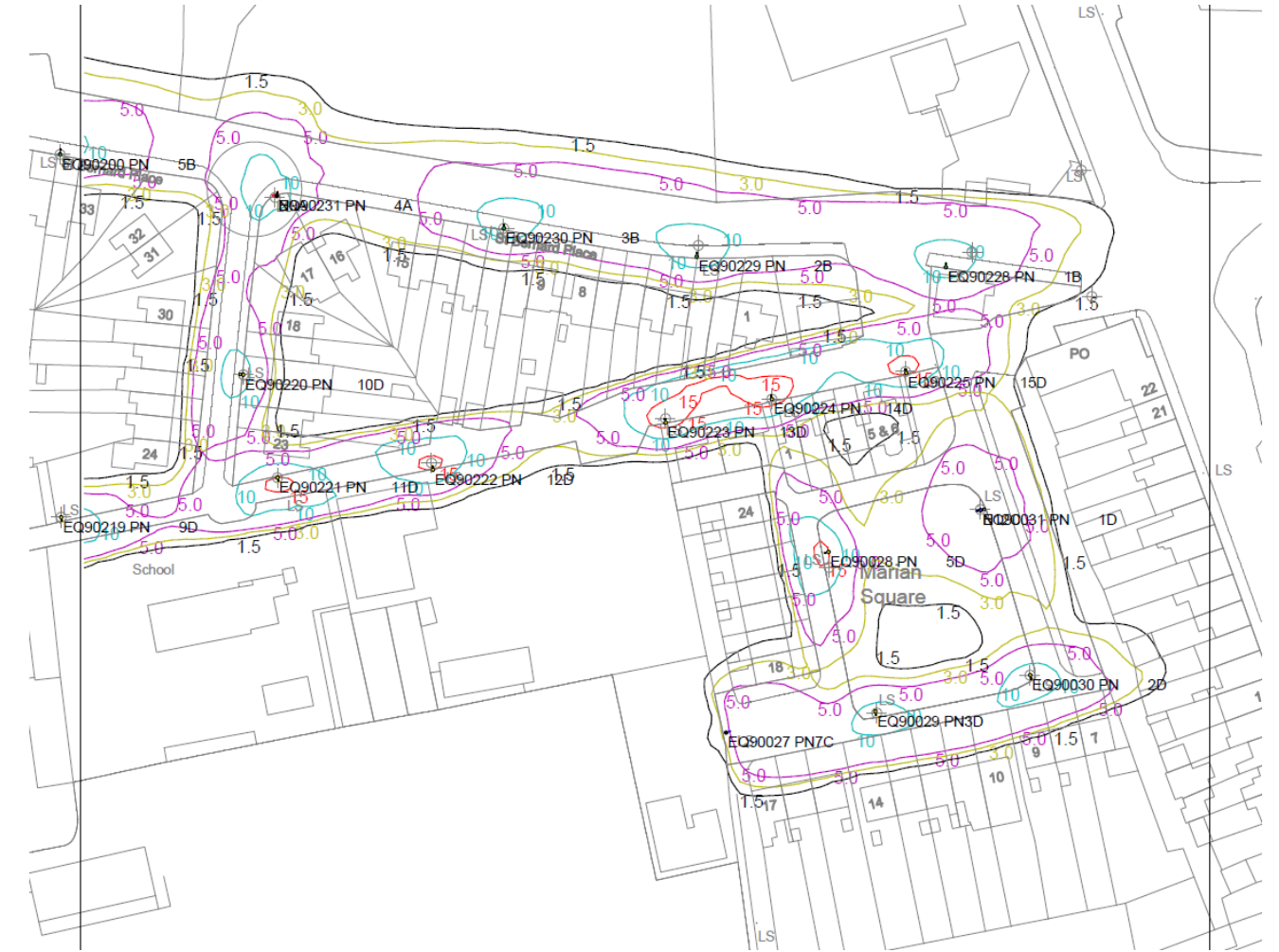

## Results

Eav	7.62
Emin	1.22
Emax	18.73
Emin/Emax	0.07
Emin/Eav	0.16

**Figure 2 : Typical Luminaire Schedule**

**Luminaires**

**Luminaire A Data**



Supplier	Philips
Type	BGP704 DW50
Lamp(s)	LED-HB 5.2S 730
Lamp Flux (klm)	17.00
File Name	Luma Gen2 Medium_BGP704_DW50_1700_80LED_5.2S_CLO_L90_730.ies
Maintenance Factor	0.84
Imax70,80,90(cd/klm)	595.5, 51.0, 0.0
No. in Project	14

**Luminaire B Data**



Supplier	Philips
Type	BGP704 DM50
Lamp(s)	LED-HB 5.2S 730
Lamp Flux (klm)	16.00
File Name	Luma Gen2 Medium_BGP704_DM50_1600_80LED_5.2S_CLO_L90_730.ies
Maintenance Factor	0.84
Imax70,80,90(cd/klm)	921.3, 65.9, 0.0
No. in Project	5

**Luminaire C Data**



Supplier	Philips
Type	BGP702 DPL1
Lamp(s)	LED-HB 5.2S 730
Lamp Flux (klm)	4.40
File Name	Luma Gen2 Micro_BGP702_DPL1_4400_20LED_5.2S_CLO_L90_730.ies
Maintenance Factor	0.84
Imax70,80,90(cd/klm)	247.8, 31.8, 0.0
No. in Project	4

**Luminaire D Data**



Supplier	Philips
Type	BGP703 DW50
Lamp(s)	LED-HB 5.2S 730
Lamp Flux (klm)	8.00
File Name	Luma Gen2 Mini_BGP703_DW50_8000_40LED_5.2S_CLO_L90_730.ies
Maintenance Factor	0.84
Imax70,80,90(cd/klm)	595.5, 51.0, 0.0
No. in Project	2

**Layout**

ID	Type	X	Y	Height	Angle	Tilt	Cant	Out-reach	Target X	Target Y	Target Z
NP1	B	537615.30	602796.49	8.00	191.00	2.00	0.00	0.00			
NP2	A	537607.09	602830.97	8.00	149.00	0.00	0.00	0.00			
NP3	E	537610.13	602859.27	8.00	301.00	0.00	0.00	0.40			
NP4	E	537652.84	602871.02	8.00	134.00	0.00	0.00	0.40			
NP5	E	537672.69	602910.10	8.00	300.00	2.00	0.00	0.40			
NP6	E	537697.45	602927.07	8.00	297.00	2.00	0.00	0.40			
NP7	E	537730.52	602924.81	8.00	104.00	2.00	0.00	0.40			
NP8	E	537765.17	602939.72	8.00	247.00	4.00	0.00	0.40			
EQ94882PN6	B	537574.60	602885.09	10.00	21.00	0.00	0.00	0.70			
NP10	E	537792.64	602909.25	8.00	82.00	4.00	0.00	0.40			
NP11	E	537821.31	602910.04	8.00	112.00	6.00	0.00	0.40			
NP12	A	537850.79	602930.87	8.00	124.00	2.00	0.00	0.40			
NP13	A	537860.58	602957.99	8.00	312.00	0.00	0.00	0.40			
NP14	A	537890.64	602982.58	8.00	308.00	0.00	0.00	0.40			
NP15	A	537930.63	603007.94	8.00	291.00	0.00	0.00	0.40			

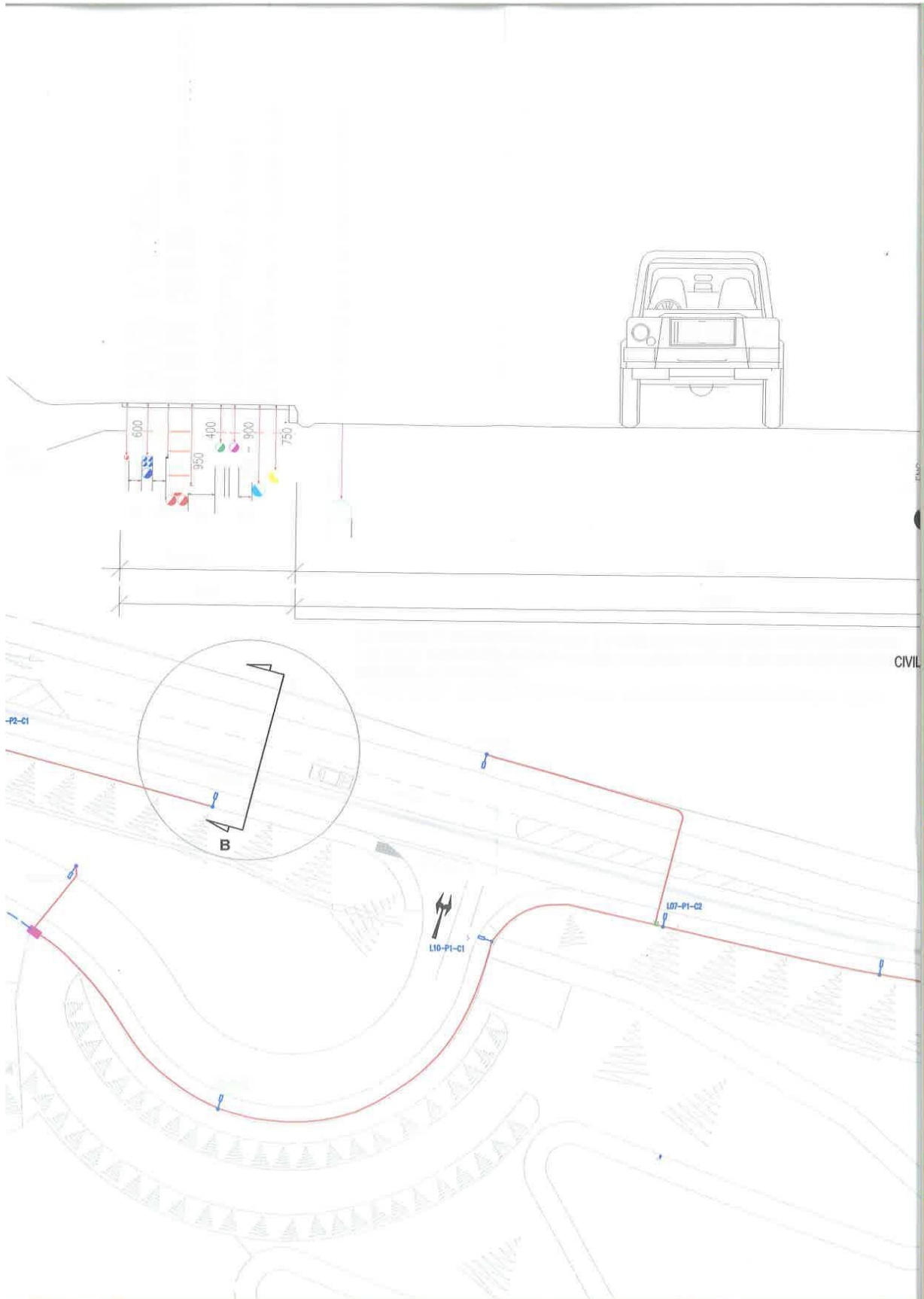

**Figure 3 Typical ducting layout and general circuitry drawing**

**Figure 4 Menu of Standard planning conditions relating to public lighting**

**General**

<b>No.</b>	<b>Condition</b>	<b>Reason</b>
DLALP P001	Public Lighting in this development shall be designed and constructed in accordance with Cork County Council's Public Lighting Manual and Product Specification 2023; a copy of which is available on Cork County Council's website, <a href="http://www.corkcoco.ie">www.corkcoco.ie</a> .	In the interest of consistency of design and compatibility for future maintenance.
DLALP P002	The following Conditions as contained in Appendix H, Figure 4, of the Cork County Council Public Lighting Manual and Product Specification 2023 shall apply to this development: - INSERT REQUIRED TEXT	In the interests of proper design and orderly development.
DLALP P003	Prior to the occupation of any houses / residences, within any phase of new development, the public lights shall be switched on in that phase and on any access roads, and shall be kept active and maintained by the developer until taken in charge by Cork County Council. Separate phases within a development shall be designed to be connected to separate midi-pillar circuits, in so far as practicable.	In the interests of public safety and to facilitate the taking in charge of the public lighting in phases if required.
DLALP P004	As part of the planning process a public lighting design and layout drawing for the section of public road along the curtilage of the site, shall be submitted to and agreed in writing with the Planning Authority, prior to development commencing.	In the interests of public safety.
DLALP P005	Public Lighting within this development shall be unmetered tariff and subject to a maximum load on individual midi-pillar connections of 2KW. Lighting shall be dimmed to profile U15, subject to a minimum of 1 Lux maintained. Lanterns shall be LED type, using brands commonly used in, and acceptable to, Cork County Council. If in doubt, the designer should contact the Council's Public Lighting Engineer, (022-30472). Lanterns shall be warm white 2,700k - 3,000k unless located at significant conflict locations such as at roundabouts, or zebra crossings, where neutral white is preferred. Any zebra crossings installed as part of this development shall incorporate auxiliary lighting designed to ILP technical report TR12.	In the interests of proper design.

<p>DLALP P006</p>	<p>Before development commences, the applicant shall submit a 'Lighting Reality' design report and drawing(s), to a minimum scale of 1/500 on A0 or A1 or A2 sized background, (ideally all on one drawing) showing lux contour levels for the designed minimum lux level, 1.5, 3, 5, 10, 15, 20...lux, as appropriate. The lux contour lines shall be of a colour and intensity that makes them easily identifiable from the background road/boundary/ducting lines and individual spot lux levels shall be omitted from the drawing to avoid clutter. The applicant shall include proposed tree locations on the Public lighting drawing to demonstrate that no trees are to be planted within 10m of a public light. The applicant shall also aim to site public lighting columns in public ground, and where appropriate columns shall be located on the boundaries between properties and not in locations where could affect the potential to extend driveways in the future. In the info box of page 1 of the Lighting report, the Designer shall include details of the CLO wattages for lights proposed (in lumen output batches) and the design classes achieved in the various design grids applicable to different elements of the design.</p>	<p>In the interest of consistency of design and compatibility for future maintenance.</p>
-----------------------	--	---

**Specific conditions to apply when used in conjunction with DLALP002**

No.	Condition	Reason
A1	All lighting within the site shall be directed and cowled as necessary so as not to interfere with traffic or cause any glare or additional light spill to adjoining residential property. The lighting must comply with requirements of the ILP Guidance Note 01/21 ‘ The Reduction of Obtrusive Light’.	In the interests of residential amenity.
A2	The developer shall liaise with the Council’s Public Lighting Engineer before removing or moving any existing public lights and shall be responsible for the cost of same. Any lights on ESB poles that have to be altered or removed can only be carried out by Electricians Authorised by Cork County Council. Currently this is confined to Electricians working for the Cork County Public Lighting Maintenance Contractor.	In the interests of public safety
A3	The lights proposed along the Public Roadway element of this development, shall be on a separate connection (MPRN) to the other lights within the development.	In the interests of separate taking in charge.
A4	All lighting points shall be accessible by means of a hydraulic hoist, for maintenance purposes. Such a hoist requires a minimum paved vehicular access of 3.0 metres. If such access is not available arrangements shall be made for the use of hinged columns.	In the interests of public safety.
A5	All electrical work shall comply with the requirements of the (a) National Rules for Electrical installations of the Electro-Technical Council of Ireland, latest edition, including Part 7, Section 714, (b) External Lighting Installation to IS 10101-2020, with minimum 6sq mm cable on mains and 2.5sq.mm flex in light standard from fuse. (c) ET213 : 2007, ET 206:2009 (d) ESB Networks Code of Practice for Customer Interface 5th Edition 2021 or subsequent latest updates.of any of the above.	In the interests of public safety.
A6	The maximum power output connected to a micro/midi-pillar shall not exceed 2KW so as to enable unmetered supply and the tariff shall be unmetered. The tariff shall be dusk to dawn for general street lighting, but dusk to midnight for recreational areas, (including recreational walkways).	In the interest of compatibility with existing Public Lighting arrangements.

A7	<p>The Developer shall liaise with the Council's Public Lighting Engineer before removing any existing public light(s) and shall be responsible for the cost and execution of any such relocation, to a location agreed with the Council's Public Lighting Engineer.</p> <p>The Developer shall demonstrate, using the services of a competent Public Lighting Engineer that the relocation of the light shall not result in any area not being adequately served by lighting, which was previously served, or shall suggest alternative/additional lighting to overcome such deficiency, if it arises.</p> <p>The Developer shall ensure that the alternative lighting arrangements are in place and operating before removing any lights or alternatively shall agree a temporary lighting arrangement, in the interim with the Public Lighting Engineer.</p>	In the interests of public safety.
A8	The Developer is to ensure that trees shall not be planted within 10m of a public lighting standard or in such a manner that the foliage is likely to obstruct the light in the future.	Canopy growth can limit the light spread and roots can disrupt underground cables.
A9	All underground public lighting cables shall be installed in their own duct.	in the interest of safety
A10	All public lighting columns, ducting for electric cables and the associated feeder pillars serving the public lights shall be installed in public areas, at the locations as per the approved Public Lighting Layout, with columns generally at the <u>back of footpaths and not in private property.</u>	To facilitate future Maintenance
A11	The public lighting will not be taken in charge by Cork County Council until all of the site has been developed and the roads, footpaths, services etc. are complete.	In the interests of Proper Planning and development
A12	At handover stage the Developer shall be provided with PL ducting layout drawings (see sample in Appendix H, Figure 3) showing micro/midi-pillar locations and detailing which lights are associated with which circuit.	Will be required to be provided to CCC PL Dept. at taking in charge stage.
A13	Public lighting columns shall be located in areas where they do not interfere with traffic especially adjacent to driveways.	In the interests of H&S and to avoid potential damage to Public Lighting columns.
A14	Lanterns shall be marine grade and columns shall be galvanized to a high standard to withstand a marine environment.	Due to the location of the site adjacent to a marine environment.
A15	The design of circuits within this development shall ensure that separate phases of the development are served by separate connections and circuits.	To facilitate the taking in charge of phases separately.



A16	Any columns erected around the perimeter of the roundabout or adjacent within 20m shall be passive columns on public roads outside of a development.	In the interest of public safety.
A17	Should the Applicant be required to construct a footpath from the proposed development to link up with the Town/village then the applicant shall install public lighting along this footpath link. The design of this public lighting will have to be submitted and agreed with the Planning Authority prior to commencement of development”	H&S for the residents for walking to the village from the proposed development
A18	Applicant shall be responsible for any damage to existing public lights/ciucuits and shall take measures to ensure their protection during the works.	In the interest of proper development.
A19	Applicant shall be aware that only Authorised Electricians are permitted to work on lights on ESB network poles. In Cork County, such Authorised Electricians are confined to the PL Maintenance Contractor.	In the interest of Health & Safety and in accordance with ESB regulations.
A20	Applicant shall ensure that the outdoor gym equipment area is adequately lit, if intended to be in use after dark and likewise any pathways leading to this area need to be adequately lit.	In the interest of Safety.
A21	The Applicant shall upgrade the public light at the entrance to a classification of “conflict Zone”. A design with a drawing showing the lux contours to be submitted for approval and agreed with the Public Lighting engineer prior to commencement of development.	Traffic Management H&S
A22	The Applicant needs to carry out a cross check between the location of the lights and trees so as to ensure that no light is within 10m of a tree so that the lights can operate effectively in later years when the foliage has matured. This effectively may require an alteration to the Landscape design.	Effective Operation of the Public Lighting
A23	The applicant is to ensure that the columns being installed are in accordance with the CCC Public Lighting Manual 2023. Plain tubular stepped columns are not desirable.	Columns Maintenance
A24	Applicant shall ensure that all external steps and ramps are lit to the appropriate standard.	In the interest of safety.
A25	The Applicant shall provide a separate power source for public lighting in the car parks of Crèches/Apartments/Commercial premises. This power source shall be from a separate source and not connected to the housing estate public lighting system.	Commercial development must be separate from the Housing Development as they do not fall into the Taking in charge category.

A26	A curfew of 11 pm shall apply to the use of floodlighting within this development.	In the interest of reducing the impact on neighbouring dwellings.
A27	All lights shall be fitted with individual photocells. These photocells shall operate with 35/18 switching or on a dusk to midnight timer for amenity area lighting.	CCC Requirements as per the PL Policy
A28	All lighting within housing estates shall be designed to use Warm White LED's	Design Requirement
A29	The public lighting including u.g. ducting, columns and lanterns shall be installed at the same time as the footpaths.	To ensure that the public lighting is installed and operating prior to the development of the individual houses.
A30	Maintenance of public lighting within this development shall remain the responsibility of the owners.	The lighting within this commercial development will not be taken in charge by Cork County Council.
A31	The applicant shall upgrade the existing lights on the access road to this development to LED's.	Due to increased level of use of the access road.
A32	The lighting of the sewerage pumping station shall be connected to the pumping station supply and shall be directed and coweled as necessary to avoid obtrusive lighting on adjacent dwellings.	Shall be the responsibility of Irish Water.
A33	In cases where the public lighting design has been approved at planning stage but it is subsequently discovered that lights need to be relocated due to overhead lines or whatever, a new lighting design shall be submitted to the planning authority for the approval of the Public lighting engineer.	In the interest of safety
A34	The design of lighting for any zebra crossings within the development shall be to TR12 standard.	In the interest of safety

**Appendix I LED LANTERN TECHNICAL CHECK SHEET for Compliance with Specification**

This is a useful check sheet to see if a particular lantern type(s) fulfills the main points of the Specification.

	Contract min standards	Luminaire Manufacturer 1	Luminaire Manufacturer 2	Luminaire Manufacturer 3
Luminaire Manufacturer, Make & Model:	-			
LED Module Manufacturer, Make & Model	-			
LED Driver Manufacturer, Make & Model	-			
Proposed Upper Limit Driver Working Current as % of max (mA)	75%			
Maximum Driver Current (mA)	1000mA			
CMS Enabled (Yes/No)				
Details of Electronic Photocell used Please state which of the following is proposed: <ul style="list-style-type: none"> <li>7-pin NEMA socket with electronic photocell</li> <li>Mini-Photocell with same functionality as 7-pin NEMA Socket</li> </ul>				
Photocell Manufacturer, Make & Model	-			
What is the manufacturer's warranty with the luminaire?	10 yrs.			
Constant Light Output (CLO) Total Circuit Watts of complete luminaire (LEDs & Driver), CLO at minimum 90% of initial lumen output for 100.000hr, i.e. L90B10	L90B10			
Does the Lantern have the CE Mark?	Yes			
What material is the Cover for the LED Modules made from?	Glass			
Confirm the on-site tilt settings of the luminaire.	10deg to +10deg for side entry in steps of 5 degs min -5deg to +10deg for post top entry in steps of 5 degs min			

	<b>Contract min standards</b>	<b>Luminaire 1</b>	<b>Luminaire 2</b>	<b>Luminaire 3</b>
Maximum Windage of luminaire	≤6M 0.15m <sup>2</sup> ≤8M 0.17m <sup>2</sup> ≤10M 0.22m <sup>2</sup>			
IP Rating	IP66			
Impact Resistance Rating (IK Rating) of luminaire (body & optic)	IK08			
Luminaire Design Life	25 yrs			
Rated Life of LED Driver	10 yrs			
Operating Voltage Range	230V ±10% (207V-253V), at 50 Hertz)			
Power Factor – for full loads and at dimming to 67% of full load output	≥ 0.9			
Surge Protection Rating (as per IEC 61643-11)	10kA/10kV			
Ambient temperature Range (Ta) luminaire is designed to operate in	-15°C to +35°C			
Upward Light Output Ratio (ULOR)	Max 0.5%			
Disability Glare Class (G Class)	G4			
Luminous efficacy of Complete Luminaire at 100% initial lumen output Minimum requirements:	Minimum of 130 lm/W for warm white 140 lm/W for neutral white			
Range of Correlated Colour Temperature (CCT) for cool, neutral and warm	2700K – 3300K warm white 4000K – neutral white			
Colour Rendering Index (CRI)	Ra ≥ 70			
LED Colour Stability (Bin Class)	Max 5-Step Ellipse			
Range of Lumen Output of the luminaire				
Can the LED module be replaced on site?	Yes			
Can the driver be replaced on site?	Yes			
Lantern housing material	Marine grade alloy			
Is access to the gear compartment via hinged or other? and how is it supported when opened and is it toughened glass? Is access a toolless operation?	Hinged Toolless operation			

End of Document